

## Inertia switch

In the event of an accident, an inertia switch will trip, isolating fuel pump operation. Once the switch has tripped it must be reset before attempting to restart the engine.

The inertia switch is located behind the trim on the right-hand side of the vehicle, forward of the front door post, below the fascia. Pull open the small panel in the trim to reset the switch.

## Resetting the switch



### **WARNING:**

**To avoid the possibility of fire or personal injury, do not reset the inertia switch if you see or smell fuel.**

If no fuel leak is apparent, reset the inertia switch as follows:

1. Turn the ignition switch to position '0'.
2. Pull open the small panel in the trim.
3. Press down the flexible cover on the top of the inertia switch.
4. Turn the ignition switch to position 'II', pause for a few seconds, then return the key to position '0'.
5. Make a further check for fuel leaks.
6. Close the trim panel.

## 6-2 Roadside emergency

---

### Emergency starting



**WARNING:**

1. It will not be possible to push or tow start a vehicle with automatic transmission.
2. Only jump lead starting or the fitting of a fully charged battery is recommended.

### Rolling start (manualtransmission only)



**WARNING:**

**Because of the dangers to other road users, extreme caution must be exercised when attempting a rolling start.**

A rolling start is pushing or towing the vehicle at low speed, in gear (preferably 2nd) with the clutch pedal depressed and the ignition switch in position 'II'.

When sufficient forward speed is obtained, the clutch pedal is gently released and the traction force from the wheels starts the engine.

### Emergency starting using jump leads

Both the booster and discharged battery should be treated with great care when using jump leads. Always use high quality leads capable of carrying the starter current of the vehicle to be started.

Before commencing, the following precautions must be taken:

- When the battery of another vehicle is being used, ensure that the vehicles do not touch. Alternatively, remove the charged battery and place near to, not on, the vehicle with the discharged battery.
- Ensure that both vehicles have all electrical services OFF, the handbrake is ON and, with automatic transmission, 'P' is selected.
- Where the jump leads are of a different colour, e.g. red and black, use red for positive (+). This aids identification and helps to avoid crossing positive(+) to negative(-). Take extra care to avoid crossing the polarity when using cables of the same colour.

### Caution:

1. If using a jump start vehicle, under no circumstances should the vehicles come into contact with each other. This could establish an earth connection, which may cause sparks and damage.
2. Do not run the jump start vehicle's engine when boost starting a Jaguar Vehicle. If the jump start vehicle's engine is running and the jump leads are disconnected, damage to the Jaguar vehicle's electrical system will result.
3. The booster battery voltage must not exceed 12volts.

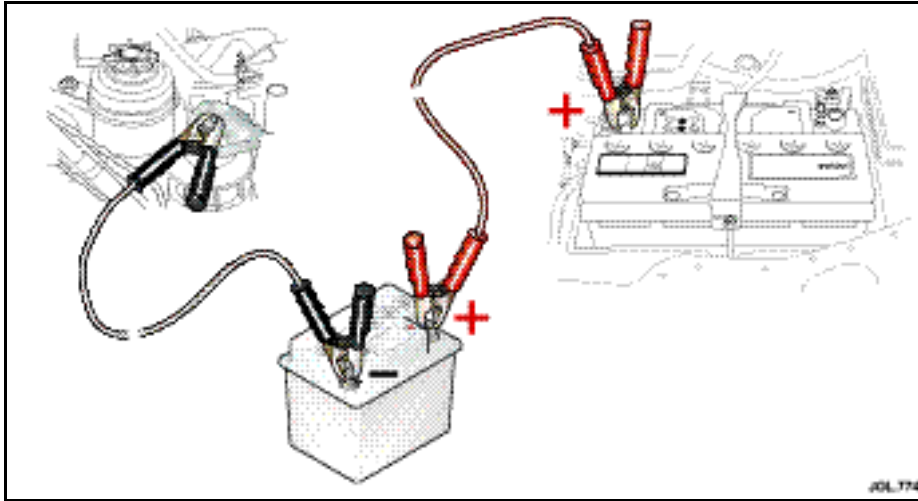

6. When started, allow the engine to idle for five minutes before disconnecting the cables.
7. Disconnect the black jump lead from the engine mount point and the booster battery negative (-) terminal.
8. Disconnect the red jump lead from the positive (+) terminals of both batteries.
9. Refit the battery box cover.

### Emergency starting using jump leads (continued)

The following procedure must be followed exactly, being careful not to cause sparks:

1. Apply the handbrake, select 'P' (automatic transmission vehicles only), and turn off all the vehicle's electrical services.
2. Open the bonnet to gain access to the battery.
3. Unclip the battery cover.
4. Attach one end of the red jump lead to the positive (+) terminal of the booster battery and the other end to the positive (+) terminal of the discharged battery. Make sure that a good connection is made.
5. Attach one end of the black jump lead to the negative (-) terminal of the booster battery and the other end to the engine mount, as shown. Make sure that a good connection is made.

**Caution:** Do not connect the negative jump lead directly to the negative (-) terminal of the discharged vehicle.

## 6-4 Roadside emergency

### Wheel changing and jacking

Be prepared for a flat tyre. Know where equipment is stowed and read the wheel changing and jacking instructions carefully. Pull off the road completely, clear of all traffic and park on as level, solid ground as possible. Switch on hazard warning lights and, where legally required, display the warning triangle.



#### **WARNING:**

**It can be dangerous to change a wheel when the vehicle is on a slope or soft, uneven ground.**

The spare wheel and jacking equipment are stored under the luggage compartment floor panel.

To remove the spare wheel, lift the luggage compartment floor panel. If a temporary-use spare wheel is stowed then the tray will need to be removed to gain access to the wheel. Unscrew the retaining nut (A) and remove the spare wheel. Remove the jack and wheel nut wrench (and locking wheel nut kit, if fitted).

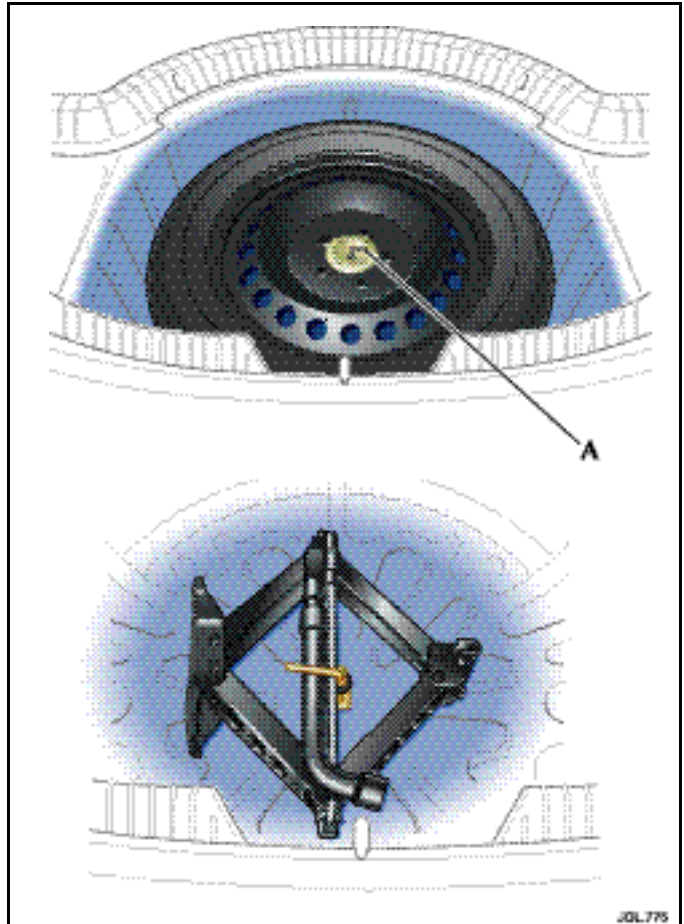

## Temporary-use spare wheel

Observe the following warnings before using the wheel.



### WARNING:

1. Please note temporary-use spare wheel warning label. Adhere to instructions on the label. Failure to comply can be dangerous.
2. When a temporary-use spare wheel is fitted, drive with caution and replace with the specified wheel and tyre as soon as possible.
3. Do not fit more than one temporary-use spare wheel and tyre assembly at one time.
4. The temporary-use spare wheel must be inflated to the correct pressure. See Chapter 8.
5. Temporary-use spare wheel, maximum speed is 50 mph (80km/h).

**Note:** Maintenance information for the temporary-use spare wheel is the same as given for normal tyres.

## Locking wheel nuts

Some vehicles are fitted with one locking wheel nut on each wheel. These can only be removed using the extractor tube and key socket located in the luggage compartment.

The locking wheel nut has a cover which makes it visually similar to standard wheel nuts. The top of the cover has an indentation (A) to aid identification.

Push the extractor tube firmly over the locking wheel nut cover, as shown at (B), until it is fully located.

Withdraw the extractor tube to remove the cover.

Fit the key socket over the locking wheel nut as shown at (C).

Fit the wheel nut wrench over the key socket and loosen the locking wheel nut.

Locking wheel nuts have a letter stamped on their upper surface. The key socket is stamped with a corresponding number. Only key sockets with the correct matching number will fit the locking wheel nut.

Should a new key socket be required, note the letter on the locking wheel nut and contact your Jaguar Dealer. Proof of vehicle ownership will be required.

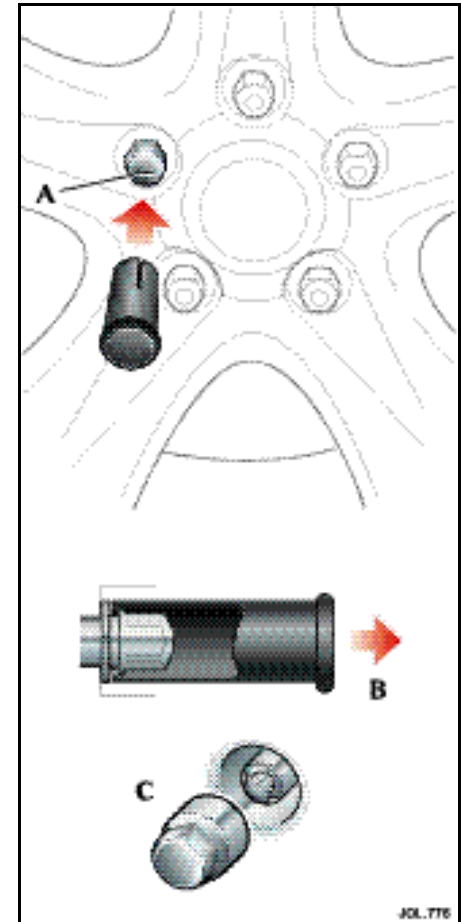

## 6-6 Roadside emergency

---

### Wheel changing

#### Caution:

1. Ensure that all passengers are in a safe place, clear of the vehicle.
2. Firmly apply the handbrake.
3. For automatic vehicles, select gear position 'P'(Park).
4. For vehicles with manual transmission, select a low gear.
5. Ensure that the jack is placed on firm and level ground.



#### WARNING:

**Before attempting to lift the vehicle with the jack, block a wheel diagonally opposite to the wheel being replaced to prevent the vehicle from rolling when jacked up.**

Before raising the vehicle, extend the telescopic wheel nut wrench and slacken, but do not remove the wheel nuts.



#### WARNING:

**Never work under the vehicle using only the jack as a support, always use axle stands or suitable supports under the jacking points.**

Observe the instructions printed on the jack.

Use the jack only for lifting the vehicle during wheel changing, and only use the jack which is stored in the vehicle.

Do not start or run the engine while the vehicle is only supported by a jack.

**Note:** When one rear wheel is lifted off the ground the selection of a low gear on manual vehicles or automatic transmission 'P'(Park) position will not prevent the vehicle from moving and possibly slipping off the jack.

**Caution:** Ensure that when anyone requires to raise the vehicle that the jack is correctly positioned to avoid any damage to the vehicle sills or sill panels. Use only the correct jacking points, never use bumpers or any other part of the body to lift the vehicle.

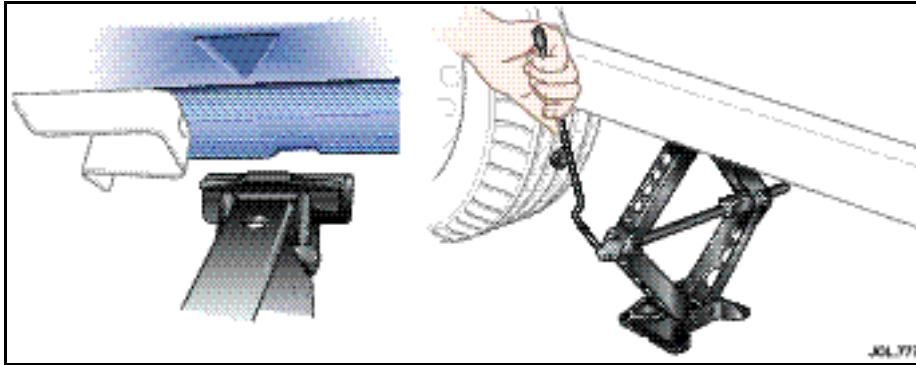

When changing the alloy road wheels, transfer the centre badge to the replacement wheel (when a full-size spare wheel is used). Using the rounded end of the wheel nut wrench handle from the inside of the wheel, push the centre badge from its housing. Push the centre badge into the replacement wheel. If the temporary-use spare wheel is to be fitted, keep the centre badge safe and fit it to the repaired full-size wheel when it has been refitted.

There are four jacking points, two each side of the vehicle on the underside of the floor. These provide positive location for the jack.

Two indented, triangular jack location points are provided on each sill cover.

The simplest way to correctly locate the jacking point is to feel along the sill panel to the triangular indentation and then fit the jack head to the body flange as shown in the illustration above.



### **WARNING:**

- 1. Do not attempt to lift the vehicle unless the jack head is fully engaged in the jacking point.**
- 2. Ensure that the handbrake is fully applied.**

Place the jack squarely beneath the appropriate jacking point. Ensure that the jack head is fully engaged. Carefully raise the vehicle by turning the handle. Stop jacking the vehicle when the tyre just clears the ground. Minimum tyre lift gives maximum vehicle stability.

Remove the wheel nuts and the wheel.



### **WARNING:**

**When the temporary-use spare wheel has been fitted, drive with caution and replace with the specified wheel and tyre as soon as possible.**

## 6-8 Roadside emergency

---

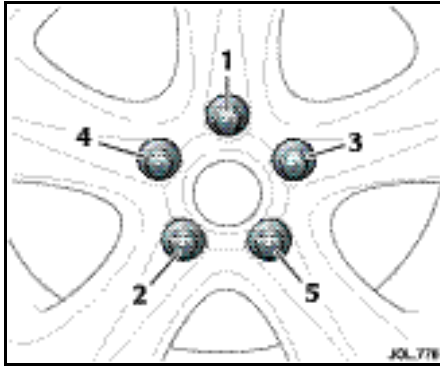

Fit the spare wheel and loosely secure with the wheel nuts.

Using the wheel nut wrench, lightly tighten the wheel nuts alternately using the sequence shown in the illustration.

Lower the jack and tighten the wheel nuts alternately, **DO NOT OVERTIGHTEN**.

At the earliest opportunity have the wheel nuts tightened with a torque wrench to:

Alloy wheels:

- 75.95 lb.ft.  $\pm$  11.4 (103 Nm  $\pm$  15.5).

Steel wheels:

- 59.0 lb.ft.  $\pm$  8.5 (80 Nm  $\pm$  12.0).

This torque must not be exceeded.

### Stowing the equipment

Stow the jack and wrench.

Stow the replaced road wheel in the luggage compartment, position the wheel and secure with the retaining nut.

Reposition the luggage compartment floor panel.

**Note:** Examine the jack occasionally and clean and grease the threads to ensure it is always ready for an emergency.



## Vehicle recovery

**Caution:** The preferred and recommended vehicle recovery method is by using a flat bed transporter.

The removable towing eye is primarily for emergency use when towing for SHORT DISTANCES, e.g. removing the vehicle if it is causing an obstruction or for winching the vehicle onto a recovery transporter.

**Caution:**

- **Do not tow the vehicle with the front wheels lifted unless the propshaft to the rear wheels is disconnected at the final drive flange. If the propshaft is not disconnected, the rotating rear wheels will force the front wheels to rotate, even with the gear selector in neutral.**
- **The vehicle can be towed with all four wheels on the ground, provided there is no damage to the transmission, for a maximum distance of 30miles (50kilometres) with the speed not exceeding 30mph (50km/h).**
- **Ensure that the recovery team do not tow with sling-type equipment since damage to the bodywork may result.**

## Vehicle failure

To prevent damage to the automatic transmission whilst the vehicle is being towed with the rear wheels on the ground, towing distance must be restricted to 0.5miles (0.8kilometres). Towing speed must not exceed 30mph(50km/h ).

Always obey towing regulations. In certain countries the registration number of the towing vehicle and an 'ON TOW' sign or warning triangle must be displayed in a prominent position at the rear of the vehicle being towed.

When being towed, the vehicle's gear selector lever must be in neutral (position 'N') with the ignition key turned to position 'II' to release the steering lock and render the indicators, horn and brake lights operational.



**WARNING:**

**When the engine is not running the steering and brakes will no longer be power-assisted. Therefore, be prepared for relatively heavy steering and the need for greatly increased brake pedal pressure.**

## 6-10 Roadside emergency

### Transporting

When the vehicle is being transported on a trailer or vehicle flat bed transporter, the handbrake must be applied, the wheels chocked and:

- the automatic gear selector lever moved to position 'N' or 'D' but NEVER to 'P'.
- the manual gear selector lever moved to the neutral position.

The vehicle must be securely tied down to the transporter or trailer. There are four transporter tie-down brackets on the vehicle underbody. Do not attach tie-down hooks to the towing eye.

### Suspended towing

Ensure that the recovery team do not tow with sling-type equipment since damage to the bodywork may result.

**Caution:** Do not tow the vehicle with the front wheels lifted unless the propshaft to the rear wheels is disconnected at the final drive flange. If the propshaft is not disconnected, the rotating rear wheels will force the front wheels to rotate, even with the gear selector in neutral.

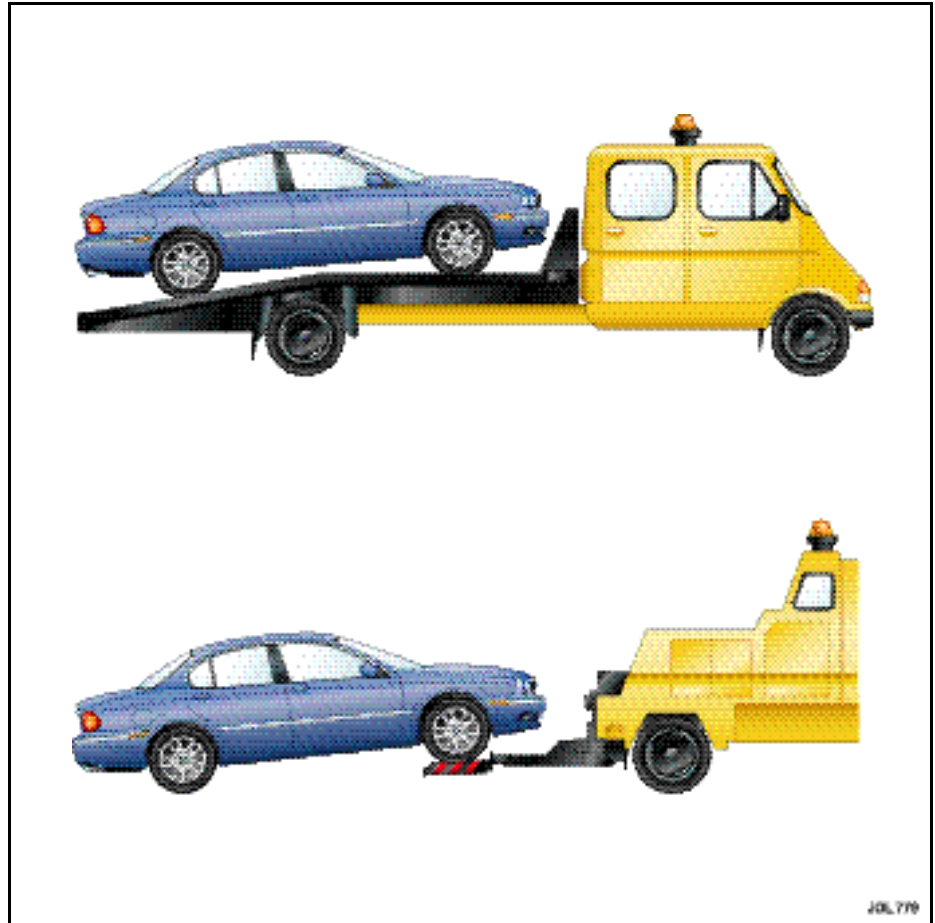

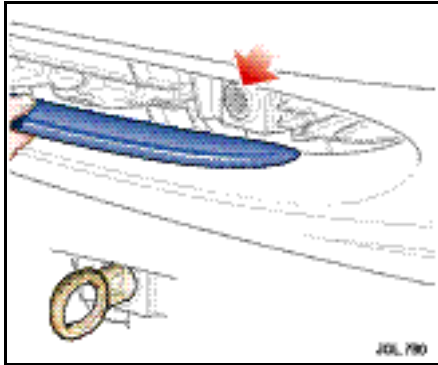

## Towing eye

A towing eye is provided in the luggage compartment with the jack.

### Caution:

- The towing eye is not suitable for 'solid bar' towing
- Care must be taken to avoid damaging the bumpers and front apron.

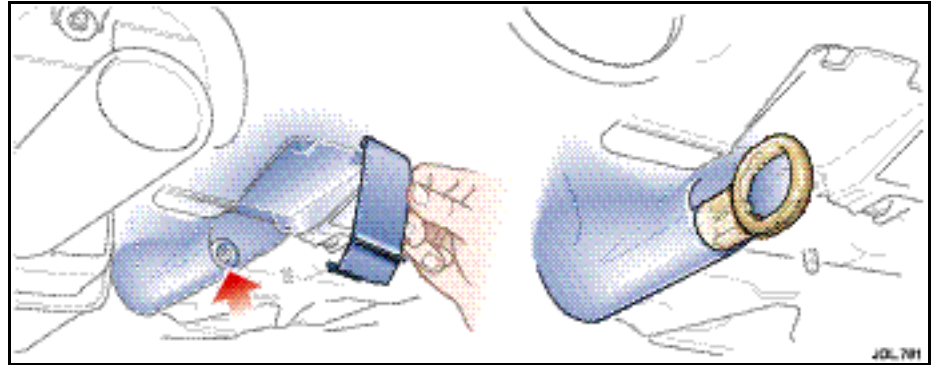

The front towing point is located at the right-hand side of the vehicle, in the grille. To prevent damaging them, the grille vane and the small cover on the left-hand side of the grille must be removed.

Pull the grill vane to remove it from the vehicle. Pull the small cover from the vehicle.

Screw the towing eye into the vehicle, right up to the shoulder.



**WARNING:**  
**Avoid body contact with a hot exhaust pipe when fitting the eye to the rear towing point.**

The rear towing point is alongside the left-hand exhaust pipe.

Remove the small cover from the bumper. Remove the bung and screw the eye into the vehicle, right up to the shoulder.

## 6-12 Roadside emergency

### Bulb renewal

It is important that only Jaguar bulbs of the type specified are used when renewing bulbs.

Before renewing bulbs, switch off the ignition and light switches.

**Caution:** Halogen type bulbs will be damaged if touched by hand or contaminated with oil or grease. It is important to use clean gloves or cloth when handling a bulb which is to be used again. A contaminated bulb may be cleaned with methylated spirit before refitting.

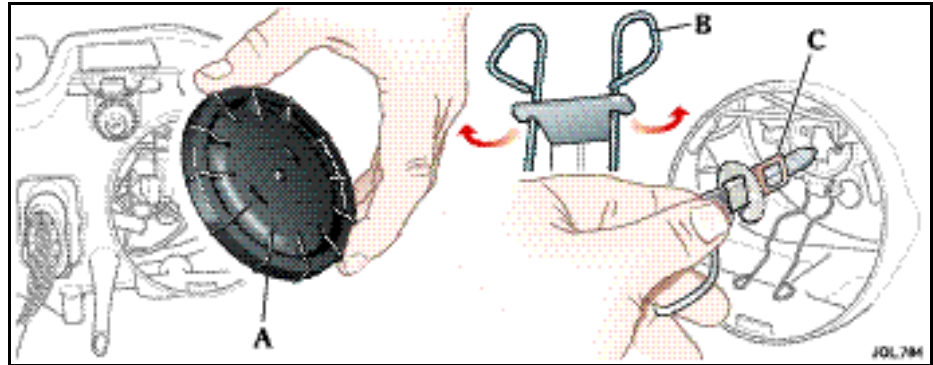

#### Main beam (inner) headlight

Open the bonnet.

Turn the circular cover (A) anti-clockwise and remove.

Press the spring clip (B) towards the bulb and downwards to release the bulb.

Remove the bulb/connector (C) from the headlight assembly. Pull the connector from the bulb.

Attach the connector to the new bulb, type H1 for main beam, and fit to the headlight. The bulb will only correctly fit in one position.

Engage the spring clips to retain the bulb and then fit the circular cover.

Refit the top cover and close the bonnet.

It is advisable to have the headlight aim checked by a Dealer after bulb renewal.



## Dip beam (outer) headlight

Open the bonnet.

Slide open the two spring clips and remove the cover.

Press the spring clip inwards and push towards the bulb to release the bulb and then remove the bulb from the light unit.

Fit a new bulb to the holder, type H1 for dipped beam.

Fit the holder to the light unit, the bulb will only correctly fit in one position.

Engage the spring clips to retain the bulb and then fit the cover and retain using the two spring clips.

Close the bonnet.

**Note:** High Intensity Discharge (HID) Xenon light units, type D2S 35W, are not renewable, contact your Dealer if the headlight fails to operate.

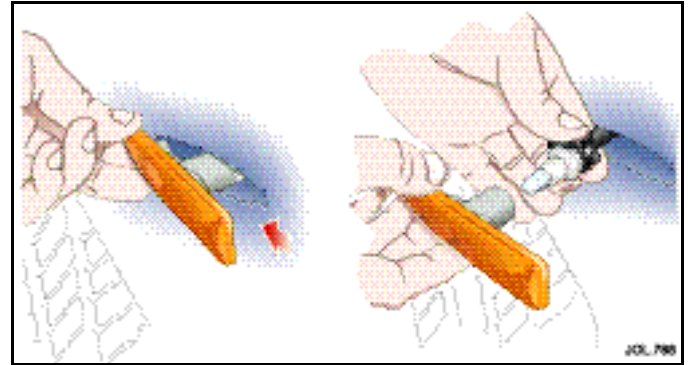

## Side repeater indicator– bulb renewal

Remove the light unit by pushing the lens towards the front of the vehicle to compress the spring clip and then pull the rear outwards to remove the complete unit.

Twist the bulb holder anti-clockwise and pull it from the lens. Pull the capless bulb from the holder and fit a new one of the correct type, W5W. Fit the bulb holder to the lens.

Place the inner rear of the lens unit into the recess and then push the front of the lens inwards until it clicks into place.

## 6-14 Roadside emergency

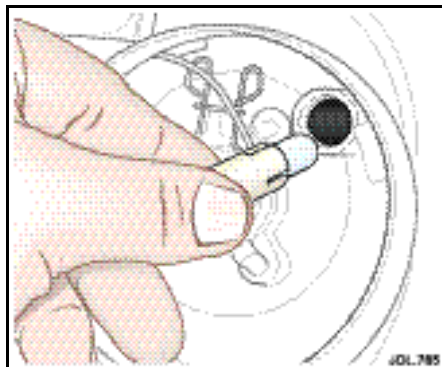

### Front parking (side) light – bulb renewal

Open the bonnet.

The front parking lights are contained within the inner headlight units.

Turn the circular cover anti-clockwise and remove.

Pull the small bulb holder from the light unit.

Pull the capless bulb from the holder and fit a new one of the correct type, W5W.

Push the bulb holder into the headlight unit.

Fit the circular cover.

Close the bonnet.

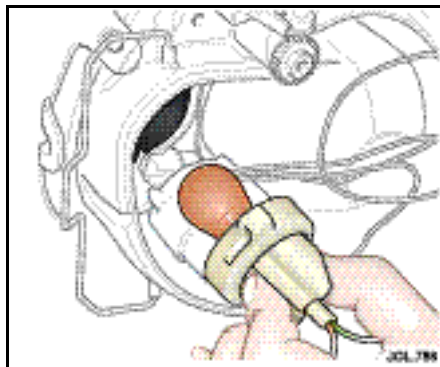

### Front direction indicator – bulb renewal

Open the bonnet.

The bulb is contained within the outer headlight.

Slide open the two spring clips and remove the cover.

Turn the holder a quarter turn anti-clockwise and remove the bulb and holder.

Remove the bulb and fit a new one of the correct type, PY21W.

Fit the holder to the light unit, it will only fit in one position.

Fit the cover and retain using the two spring clips.

Close the bonnet.

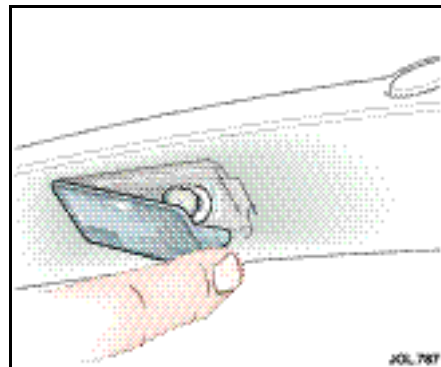

### Number plate light – bulb renewal

Push the lens clip sideways and remove the lens from the vehicle.

Remove the bulb and fit a new one of the correct type, W5W.

Refit the lens by pressing it firmly into the recess until it clicks into place.

### Front fog light – bulb renewal

It is recommended that the front fog light bulb, type H1, is renewed by a Jaguar Dealer.

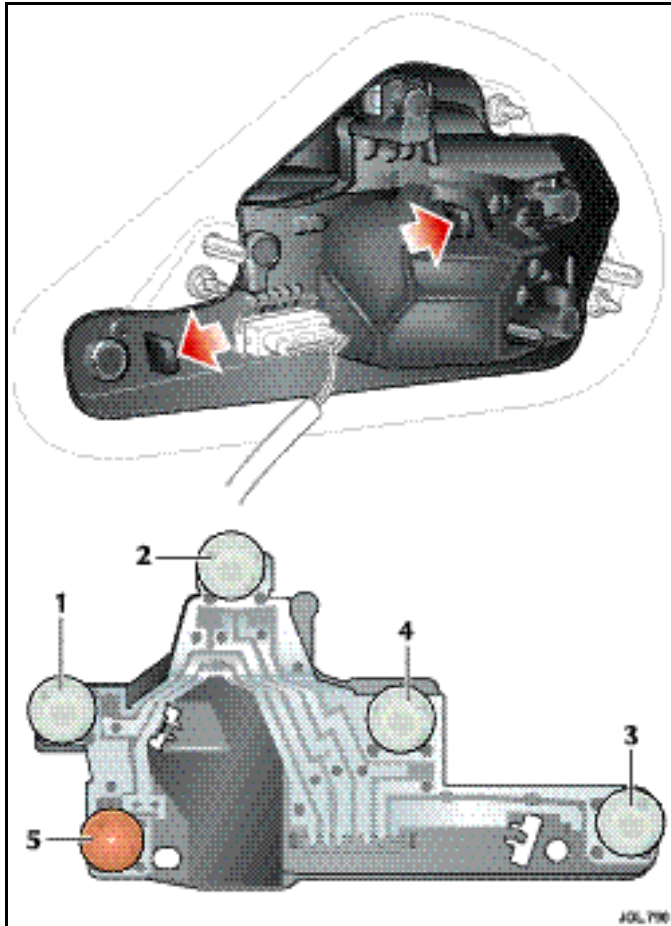

## Rear light assembly– bulb renewal

The rear light assembly has the following bulbs:

1. Reverse light, type P21W.
2. Stop/tail light, type P21/5W.
3. Fog light, type P21W.
4. Tail light, type P21/5W.
5. Direction indicator, type PY21W.

Ensure that the lights and ignition switch are OFF before removing any bulbs.

Open the luggage compartment, loosen the side carpet and unclip the rear light bulb carrier.

Remove the faulty bulb and fit a new one of the correct type, as illustrated on the bulb holder. Fitment of the correct type is essential.

Refit the bulb carrier assembly, ensuring that the clips are correctly secured.

Refit the carpet.

## High mounted stop light

The high mounted stop light is an LED type. Should one or more LED's fail then the unit may cease to meet legal requirements and must be renewed immediately by a Jaguar Dealer.

## 6-16 Roadside emergency

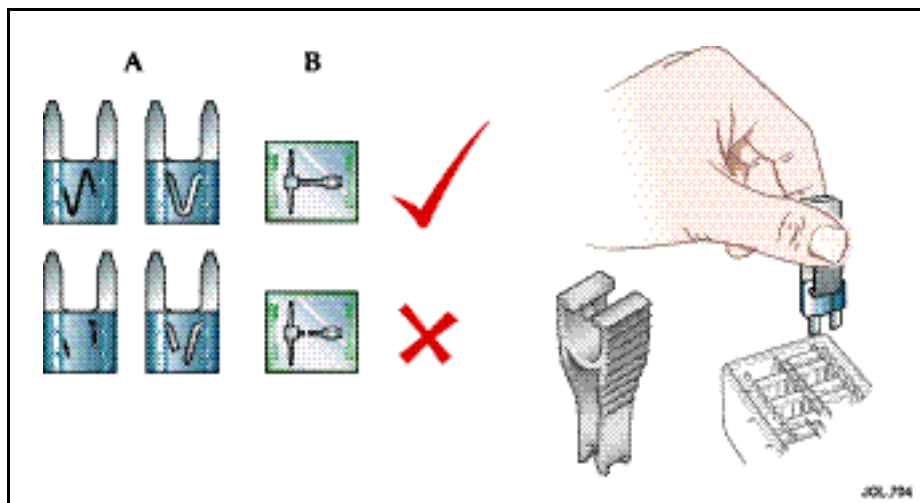

### Fuses and fuse boxes

Fuse failure is identified by an inoperative circuit.

Do not fit a new fuse if the wiring is damaged; contact a Jaguar Dealer. After renewing a fuse have the circuit checked by a Jaguar Dealer.

Two types of fuses are fitted in the fuse boxes, a mini-type (A) and a cartridge-type (B).

A special tool for removing and replacing the mini-fuse is provided in the engine compartment fuse box lid, together with spare fuses.

Use only the spare fuses supplied. If a spare fuse is used, renew it with a Jaguar approved fuse of the **same** amperage rating.

### Checking and renewing a blown fuse

Make sure the new fuse is the correct rating (amperage).

Fuses are colour coded according to the amperage and the rating is also marked on each fuse.



## Mini-fuse replacement

Push the tool on to the suspect mini-fuse and withdraw it.

If the wire in the fuse is broken, the fuse has blown.

Fit a new fuse using the tool.

## Cartridge fuse replacement

Pull the suspected blown fuse from its holder.

If the wire in the fuse is broken, the fuse has blown.

Push a new fuse into the holder.



### **WARNING:**

- 1. Do not fit a fuse of a different amperage from that removed. The electrical circuits may become overloaded with the subsequent possibility of a fire.**
- 2. No attempt should be made to repair a fuse that has blown as this may cause a fire hazard or serious damage elsewhere in the electrical circuit.**

## Fuse box locations

There are two separate fuse boxes fitted to the vehicle, each one containing fuses protecting a different group of circuits.

They are located in:

- A.** the engine compartment
- B.** the passenger compartment

**Caution:** When a fuse box lid is removed, take care to protect the box from moisture, and refit the lid at the earliest opportunity.

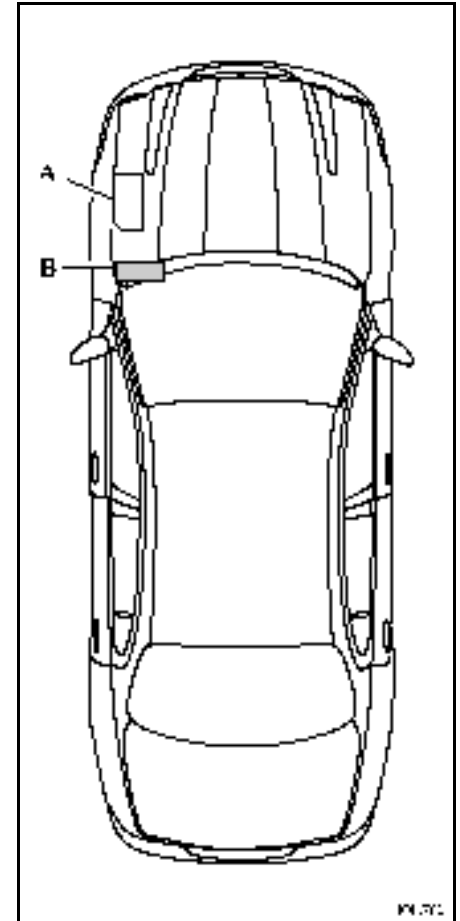

## 6-18 Roadside emergency

---

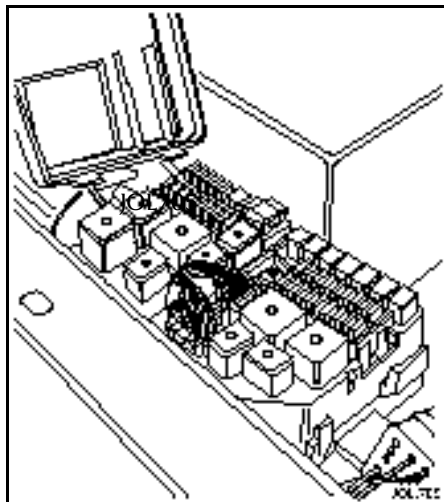

### Engine compartment fuse box

The fuse box is located in the engine compartment on the left-hand side adjacent to the battery.

Remove the fuse box lid by pressing the retaining lugs and lifting.

A tool for removing the mini-fuses is located in the fuse box cover.

When refitting, press the fuse box lid in the area of the retaining lugs until the lid engages.

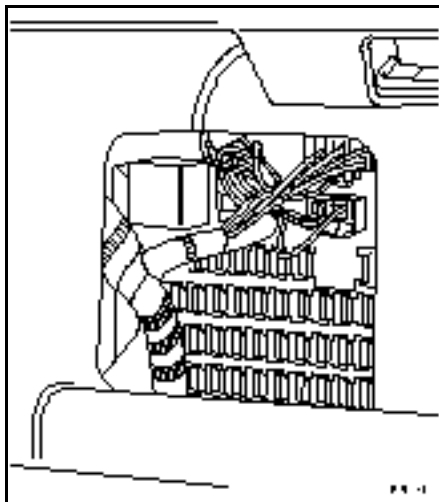

### Passenger compartment fuse box

The passenger compartment fuse box is located on the left-hand side of the vehicle, against the bulkhead.

A tool for removing the mini-fuses is located in the engine compartment fuse box cover.

### Right-hand drive vehicles

To gain access to the fuse box, open the glove compartment and remove the panel at the front of the compartment.

### Left-hand drive vehicles

For fuse box visual access, remove, by unclipping/pulling, the sunglasses stowage compartment, to the left of the steering column.

A torch or flashlight will be required to properly identify the fuses.

Fuse and Relay Positions

A- Engine compartment fuse box

B - Passenger compartment fuse box

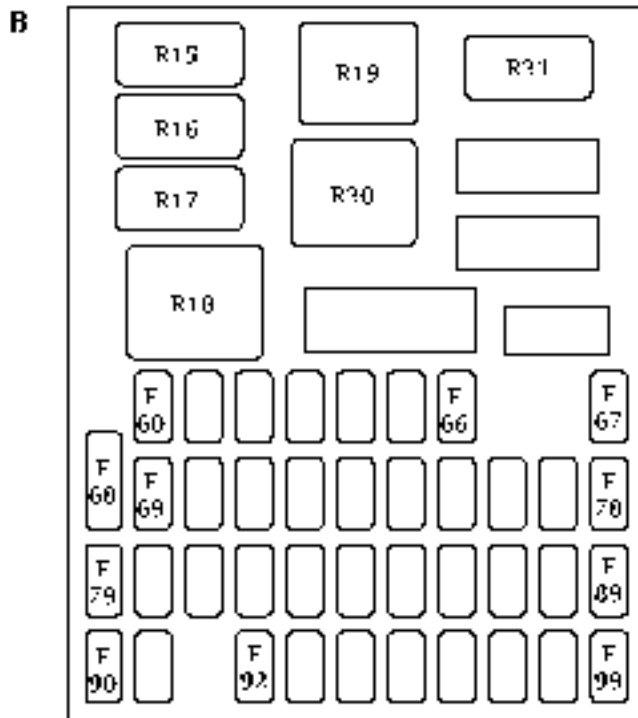
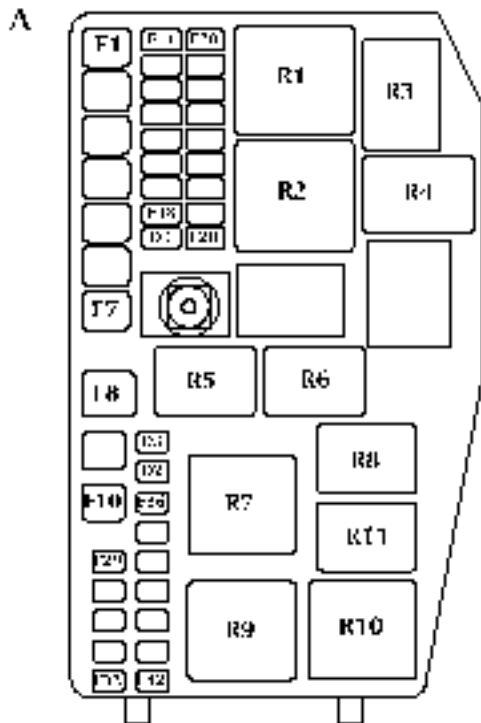

## 6-20 Roadside emergency

---

### Engine compartment fuse box – fuses

Fuse No	Fuse Type	Rating (amps)	Colour	Circuit
F1	cartridge	20	Blue	Dip beam, High Intensity Discharge(HID) light relay.
F2	cartridge	50	Red	Ignition relay feed.
F3	cartridge	60	Yellow	ABS.
F4	cartridge	30	Pink	Rear window heater relay, heated mirrors.
F5	cartridge	30	Pink	Auxiliary vacuum pump, transmission control module.
F6	cartridge	30	Pink	Heater blower relay.
F7	cartridge	50	Red	Power supply to passenger compartment fuse box.
F8	cartridge	80	Black	Fan module.
F9	cartridge	50	Red	Engine management system power relay, headlight power wash.
F10	cartridge	20	Blue	Headlight power wash relay.
F11	mini			Not used.
F12	mini			Not used.
F13	mini	30	Green	Heated front screen right-hand side.
F14	mini			Not used.
F15	mini	30	Green	Heated front screen left-hand side.
F16	mini	20	Yellow	Left-hand dip beam, DTRL, autolights.
F17	mini	20	Yellow	Right-hand dip beam, HID lights.

## Roadside emergency 6-21

Fuse No	Fuse Type	Rating (amps)	Colour	Circuit
F18				Not used.
F19	Diode D1			Not used.
F20	Mini	5	Tan	Navigation display.
F21	Mini	15	Blue	Master lighting (Park lights).
F22	Mini	20	Yellow	Accessory relay.
F23	Mini	10	Red	Air conditioning compressor clutch relay.
F24	Mini	15	Blue	Door lock power.
F25	Mini	15	Blue	Direction indicators (GEM).
F26	Mini	15	Blue	Horns relay.
F27	Mini	10	Red	Transmission control module, transit relay.
F28	Mini	30	Green	Ignition switch.
F29	Mini	30	Green	Starter motor relay.
F30	Mini	30	Green	Accessory sockets.
F31	Mini	10	Red	Engine management relay coil.
F32	Mini	5	Tan	Engine management control.
F33	Mini	20	Yellow	Throttle motor relay.
F34	Diode D3			Not used.
F35	Diode D2			Diode EMS relay.

## 6-22 Roadside emergency

---

Fuse No	Fuse Type	Rating (amps)	Colour	Circuit
F36	Mini	10	Red	Canister purge valve, canister close valve, airflow meter, throttle motor relay, power wash relay coil, air conditioning relay coil.
F37	Mini	15	Blue	Engine management system, fan speed controller, speed controller.
F38	Mini	30	Green	Oxygen sensor heatersA.
F39	Mini	5	Tan	Variable intake valves.
F40	Mini			Not used.
F41	Mini	10	Red	Injectors.
F42	Mini	30	Green	Oxygen sensor heatersB.

## Engine compartment fuse box – relays

Fuse No	Fuse Type	Rating (amps)	Colour	Circuit
R1	ISO 40 A	40A	Black	Windscreen wipers.
R2	ISO 70 A	70A	Grey	Heated front windscreen.
R3	Micro 20 A	20A	Black	Horn.
R4	Micro 20 A	20A	Black	Accessories.
R5	Micro 20 A	20A	Black	Headlight powerwash.
R6	Micro 20 A	20A	Black	Air conditioning compressor clutch.
R7	ISO 70 A	70A	Grey	Engine management system.
R8	Micro 20 A	20A	Black	Transmission control module.
R9	Micro 20 A	40A	Black	Dip beam/HID.
R10	ISO 40 A	40A	Black	Starter motor.
R11	Micro 20 A	20A	Black	Throttle motor.

## 6-24 Roadside emergency

---

### Passenger compartment fuse box – fuses

Fuse No	Fuse Type	Rating (amps)	Colour	Circuit
F60	Mini	20	Yellow	Power windows left-hand.
F61	Mini	20	Yellow	Power windows right-hand.
F62	Mini	10	Red	Rear fog lights.
F63	Mini	10	Red	Right-hand– front side light, side markers, rear tail lights.
F64	Mini	10	Red	Left-hand – front side light, side markers, rear tail lights.
F65	Mini			Not used.
F66	Mini	30	Green	Left-hand power seat switches and heater module.
F67	Mini	5	Tan	Battery back-up sounder, transit relay, HID/dip relay, auxiliary vacuum pump control.
F68	Mini	15	Blue	Cigar lighter.
F69	Mini	10	Red	In-car entertainment head unit, antenna module, navigation module, VICS, tuner, voice module, parking aid, amplifier premium 1 system, phone handset, phone power supply module, instrument cluster, PATS module.
F70	Mini	30	Green	Right-hand power seat switches and heater module.
F71	Mini	15	Blue	VICS (Japan), voice module, telephone transceiver, telephone handset.
F72	Mini	15	Blue	Radio head unit, CD player, navigation electronic control module, Jaguardiagnosticconnector/OBD2 connector.
F73	Mini	15	Blue	Sunroof unit/module.
F74	Mini	15	Blue	Instrument cluster, Premium ICE amplifier unit.



Fuse No	Fuse Type	Rating (amps)	Colour	Circuit
F75	Mini	10	Red	Mirror fold-back module, battery back-up sounder, air conditioning ECU.
F76	Mini			Not used.
F77	Mini	10	Red	Screenwash pump, rain sense.
F78	Mini	5	Tan	Phone power supply, Jaguar Telematics.
F79	Mini	10	Red	Reverse lights, reverse light switch, reverse park aid, electrochromic mirror, instrument cluster.
F80	Mini	10	Red	Park interlock, heater switch, OBD2, blower relay.
F81	Mini	20	Yellow	Fuel pump.
F82	Mini	20	Yellow	Manual transmission reverse lights, variable power steering, alternator, TCM.
F83	Mini	10	Red	Left-hand and right-hand heated seats modules.
F84	Mini	5	Tan	Instrument cluster, pad light, seat weight sensor.
F85	Mini	10	Red	Right-hand high beam light.
F86	Mini	10	Red	Left-hand high beam light.
F87	Mini	15	Blue	Front fog lights, master light switch.
F88	Mini			Not used.
F89	Mini			Not used.
F90	Mini	15	Blue	Stop lights, cruise control.

## 6-26 Roadside emergency

---

Fuse No	Fuse Type	Rating (amps)	Colour	Circuit
F91	Mini	10	Red	Sunroof, electrochromic mirror, left and right-hand power windows.
F92	Mini	10	Red	Manual transmission cruise control switch, ignition coils, automatic transmission rotary switch.
F93	Mini	30	Green	Windscreen wipers.
F94	Mini	20	Yellow	HID module.
F95	Mini	10	Red	Airbag restraints module.
F96	Mini	10	Red	ABS module.
F97	Mini	10	Red	Glove compartment light, instrument cluster lights, licence plate lights.
F98	Mini	10	Red	Mirror heaters.
F99	Mini	10	Red	Footwell lights, luggage compartment light, puddle lights, vanity mirror lights, interior lights, aircon control unit, roof console unit.

## Passenger compartment fuse box- relays

Relay No	Type	Rating (amps)	Colour	Circuit
R15	Micro 20 A	20A	Black	High beam/front fog lights relay.
R16	Micro 20 A	20A	Black	Not used.
R17	Micro 20 A	20A	Black	Reverse lights.
R18	ISO 70 A	70A	Grey	Ignition relay.
R19	ISO 40 A	40A	Black	Heated rear window relay.
R20	ISO 40 A	40A	Black	Blower relay.
R21	Micro 20 A	20A	Black	Battery saver relay.

