

Audio System

GENERAL INFORMATION

The vehicle audio system interacts with the in-car phone system via data on the multiplex communications vehicle network.

The audio system can be controlled from either the radio panel or multi-function controls on the left-hand side of the steering wheel.

The sound system antenna is an integral part of the vehicle backlight for saloon versions, and rear side window for estate versions.

Caution: Care must be taken to avoid spilling or splashing drinks onto the audio system head. In the event of such an occurrence advise your Jaguar Dealer/Authorised Repairer.

Do not use petrol, solvents or abrasive cleaners on the audio system. Wipe the surface with a lint-free cloth to remove dust. Slightly moisten the cloth with clean water to remove any finger marks from the outside surface.

If the unit is to be removed or the battery disconnected, first ensure that the radio code is recorded. The number will be required for re-insertion following radio installation.

SECURITY CODE NUMBER

For the United Kingdom and European countries, the audio head unit is protected by an anti-theft security code. If power to the radio drops to 5 volts or less (dead battery), or there is a power interruption/disconnection, the radio display will indicate **CODE**. At this point the radio will not operate until the correct security code is re-entered.

The four-digit code which is listed on an audio security card supplied with the vehicle, is entered by pressing preset buttons **1** to **9**. A beep indicates that the code has been entered correctly.

If the code is entered incorrectly, two further attempts at code entry will be permitted. If, after three successive attempts, the code has not been properly entered, the display will indicate **PLEASE WAIT**. In this condition the radio will not accept further entries until it has been left on for at least 30 minutes. After 30 minutes the radio will accept three further entries.

Note: *In the event of loss of your radio security card, contact your Jaguar Dealer/Authorised Repairer who, for security reasons, will require proof of vehicle ownership.*

Audio System

COPYRIGHT LAWS

Caution: Copyright laws vary in different countries; please check the laws in your country if you want to record from copyright source material.

Caution: Due to technical incompatibility, recordable (CD-R) discs and rewritable (CD-RW) discs may not function correctly.

Caution: These CD units will play compact discs that conform to the international Red Book standard audio specification. Copy protected CDs from some manufacturers do not conform to this standard and playback cannot be guaranteed.

Caution: Dual format, dual-sided discs (DVD Plus, CD-DVD format), now being adopted by the music industry, are thicker than normal CDs and consequently playback cannot be guaranteed in Jaguar audio units, and jamming could occur. Warranty claims, where this type of disc is found to be inside an audio unit returned for repair, will not be accepted.

Caution: Irregular shaped CDs and CDs with a scratch protection film or self-adhesive labels attached should not be used.

AUDIO SYSTEM CARE

Radio

Do not use petrol, solvents or abrasive cleaners on the radio. Wipe the surface of the radio with a lint-free cloth to remove dust. Slightly moisten the cloth with clean water to remove any finger marks from the outside surface of the radio.

If the radio is to be removed or the battery disconnected, first ensure that the radio code is recorded. The number will be required for re-insertion following radio installation or battery reconnection.

Compact Discs (CDs)

When handling CDs, do not touch the playing surface. CDs should be stored in their cases away from direct sunlight, heat and dust. Scratches, fingermarks or dust on the surface of a disc can cause the optical pick-up to skip tracks. If the surface of a CD is dirty, use an appropriate CD cleaner.

Do not attempt to play discs that are damaged, warped, cracked or of incorrect size. They can seriously damage the playback mechanism.

Steering Wheel Controls

STEERING WHEEL CONTROLS

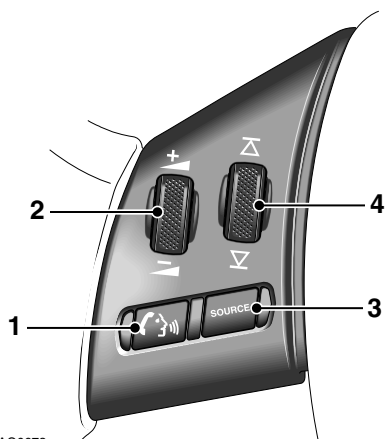

JAG0673

Four audio system control switches are situated on the left-hand side of the steering wheel. Duplicating the functions of buttons on the audio panel, these provide fingertip control of audio and telephone systems whilst driving.

1. Press to start a voice session, or mute when JaguarVoice is not fitted.
Answer phone call when ringing.
Send/End when in phone mode.
2. Press as required to increase or decrease volume.
3. Press and release to cycle through DAB, FM, AM, CD and CD Changer, or press and hold for at least two seconds to select Phone Ready mode.
4. Press as required and release to cycle through preset radio stations, the next CD track.
Press and hold for at least two seconds to cycle to next strong station or next CD.

Radio

GENERAL INFORMATION

Reception

FM reception offers the advantages of low noise interference, minimal distortion, wide dynamic range, extended frequency response, and is usually broadcast in stereo. FM frequency waves are however relatively short and travel in a straight line and can therefore be impeded by obstructions, which may adversely affect reception in certain parts of the country. This is a condition known as multipath interference.

Whilst FM reception generally provides better quality sound, AM reception or Medium Waveband (MW) and Long Waveband (LW) (United Kingdom and Europe) may prove superior in remote areas not covered by the shorter range FM transmitters.

When experiencing poor FM reception, background noise can be reduced by pressing the **MODE** button, selecting **TREBLE** and reducing the treble setting.

Radio Data Systems (RDS) and Traffic Announcements (TA)

Jaguar sound systems are equipped with Radio Data System (RDS) which assists in locating and remaining tuned to a selected radio station.

When tuned to certain stations on the FM waveband, the radio decodes signals transmitted, to provide the following functions (dependent upon the service available):

- When **RDS** is selected the station name is displayed in eight characters.
- Automatic retuning to follow network stations:

RDS provides fully automatic radio tuning for network stations. It tunes to a signal not a frequency. RDS will locate the strongest signal available for a given station.

- RDS will automatically switch frequencies (AF Switching) as necessary. This function can be toggled off and on by pressing and holding the **AM/FM** button.

- RDS station/programme type display and search:

RDS displays information on the type of material broadcast by the station or programme that is on e.g. **News**, **Classical**, **Rock** etc. In addition to this function, the radio can search for a selected programme type.

- RDS priority Programme Type (PTY) auto retuning (where broadcast):

Similar to Traffic Announcement (TA) this can be selected to interrupt and switch to the selected programme type e.g. **News**, for its duration.

- Local radio station traffic information (where broadcast):

RDS provides travel information relevant to the vehicle location. On learning of a traffic problem, the authorities inform the nearest local radio station.

The traffic announcement (TA) is then broadcast by transmitters in the relevant area.

Provided **TA** has been selected, traffic announcements will interrupt radio or CD play, on all equipment with the RDS feature. If the volume control is set at minimum it will automatically increase to an audible level for the duration of the traffic news flash.

When the traffic announcement has been completed, the system reverts to the driver's original listening choice and volume setting.

Radio

RDS operation



To activate RDS, press the **TA** button and hold for at least two seconds until **RDS ON** is displayed.

To deactivate RDS, press the **TA** button and hold until **RDS OFF** is displayed.

With the radio tuned to an RDS station and RDS activated, the radio gathers RDS information and displays the service name/data.

If the radio is not tuned to an RDS station, it will remain on that station and display the frequency, and RDS will remain on in readiness for a signal.

When listening to a national network station, or a station that broadcasts on more than one frequency, the radio will retune to the strongest available signal (AF Switching). This 'network following' will continue throughout the journey. (Unselected presets will also receive new frequency information, if appropriate.)

When RDS data is lost and no alternative frequency signal is available, the radio will stay on station, the display shows the frequency only and RDS remains on in readiness for the signal to recover.

If the **RDS** function does not respond correctly, see '*RDS troubleshooting guide*', page 256.

TA operation

To activate **TA**, press the **TA** button briefly (less than two seconds).

TA will appear in the display. The radio then checks that the station has RDS TP (Traffic Programme); indicated by **TP** at the top of the display. If **TP** is not available on the current station, the display will show **TP SEEK** while it searches for a station that does have it.

If a **TA** station is not available, a beep is sounded and **TA** is removed from the display.

With **TA** activated, traffic announcements will interrupt radio or CD play. If set at a minimum, the volume will increase for the announcement, returning to normal setting afterwards. When receiving, the display will show **TRAFFIC INFO**.

To deactivate **TA**, briefly press **TA** (less than two seconds).

Preset TA volume

When the radio is set to minimum volume and a traffic announcement occurs, the volume is raised to a preset level. This level can be adjusted by pressing and holding the **MODE** button for more than two seconds, then setting the volume level (which is displayed) between **1** (min.) and **6** (max.) by turning the volume control knob.

Programme Type (PTY)

(Where broadcast)



This has two functions: To display the current station programme type and to select a programme type and retune to it.

Momentarily press the **PTY** button to display the current station programme type. Use the tuning buttons to cycle through the available programme types, press the **PTY** button again to activate a search for the selected programme type. If there is a station with the correct **PTY** then the radio will retune to it. If not, the radio will indicate **NO PTY** and return to the current station.

Priority Programme Type (PPTY)

Functions as an interrupt or as a '**PTY Following**'.

Radio

Press and hold the **PTY** button to activate the selected priority programme type, **PPTY**. The radio will now wait for RDS information to indicate that a station has changed its programme type, e.g. to **NEWS**. The radio will now retune to the new station for the duration that it remains on that programme type.

If the current station is already on the selected priority programme type, then when this station is lost, the radio will attempt to find another with the correct programme type.

To cancel Priority Programme Type, press and hold the **PTY** button, the **PTY** indicator will clear from the display.

Note: *TA and PPTY interrupt feature is also available in CD and audio modes.*

TA and priority PTY interrupt skip

Interruptions for traffic announcements, news or other selected priority programme types, can be skipped by pressing **TA** during the interrupt. The radio returns to the previously selected audio source.

Note:

- *Interrupt skip will not cancel activation of **TA** or **PPTY** and it will remain ready for the next interrupt.*
- ***TA**, **PTY** and **PPTY** features are reliant upon the broadcast information from radio stations, and may be much better in some areas than others.*

PTY31-ALARM (where broadcast)

When using the radio with **RDS** selected, a **PTY31-ALARM** service will operate, to alert on any crises of major national importance. When such a broadcast is made, **ALARM** will appear in the audio display.

Radio

RDS troubleshooting guide

Incorrect response from RDS	Reason and rectification
Radio does not display programme name.	Check that RDS is turned on by pressing and holding the TA button until the display confirms RDS ON . If the radio does not display a programme service name, it is not broadcasting RDS data, or you are in a poor reception area. Try retuning to another station with RDS.
Station name is lost and displays frequency only.	Radio has lost reception of the RDS data due to vehicle moving out of transmitter range, loss of signal in a tunnel, under a garage forecourt canopy, or similar screening. If the latter is the case, when the vehicle is clear of the screening, the station name will return after a short delay.
Upon operating A MEM , NO FM is displayed when most or all of the preset positions are selected.	The radio cannot locate nine FM, RDS FM or TP stations dependent upon the mode selected. If this occurs, switch off RDS or TA and reselect A MEM .
Upon pressing the TA button the radio retunes to another station and displays TP SEEK .	The station selected does not have TP/TA facility, the radio will retune to one that does.
Radio sound goes off and the display shows PI SEEK .	The RDS radio station selected is unable to confirm that the frequency tuned to has the correct RDS data – Programme Identification (PI). It will then seek for a frequency that has the correct data.
Radio ‘beeps’ and the display shows NO TA/TP and turns off TA .	The vehicle is in an area where TA broadcasts cannot be received from any FM stations. The radio will automatically de-select the TA feature.

Radio

RADIO - STANDARD AUDIO

Audio system display panel

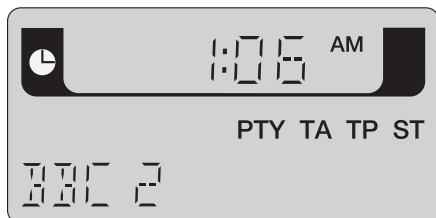

JAG0992

Shown in AM/FM mode

On/Off and volume control



Press the control knob to switch the radio on, press again to switch off. Turn the control knob clockwise to increase or counter clockwise to decrease volume.

Any volume setting made whilst in audio, phone, or voice activation mode, will be memorised for that system.

Automatic Volume Control (AVC)

This maintains radio volume at a level sufficient to overcome road noise as vehicle speed increases or decreases.

To activate AVC, press and hold the volume control knob until **AVC** is displayed. To deactivate AVC, briefly press the volume control knob again. The level of AVC control can be adjusted by turning the volume control knob whilst in **AVC ON** mode. When AVC is ON, manual adjustment of volume will override the AVC setting.

MODE button



The **MODE** button functions at two levels. Mode level 1 is used to adjust sound performance. Mode level 2 can be used to adjust the audio display clock, to adjust **Traffic Announcement (TA)** and Voice Activation volume and to select Voice Activation Training.

Mode level 1

A short press and release of the **MODE** button will access the mode level 1 menu. Subsequent short presses of the **MODE** button will scroll through the available modes. When the desired mode is displayed, use the rotary volume control to adjust the setting.

Available modes

BASS	Increase/decrease
TREBLE	Increase/decrease
BALANCE	Left to right
FADE	Front to rear
SUB LEVEL	<i>Premium audio only.</i> Increase/decrease subwoofers
DSP POSITION	See Digital signal Processing (DSP) text
ADVANCED MODE	Allows access to mode level 2. When ADV MODE N/Y is displayed, turn the rotary volume control to select ADV MODE YES . Subsequent short presses of the MODE button will scroll through the mode level 2 menu.

Digital Signal Processing (DSP) (Premium audio system only)

Radio

DSP can optimise sound performance for specific seating positions. To adjust the setting:

- In Mode level 1, scroll to **DSP POSITION**.
- Use the rotary volume control to cycle through **POS F-LEFT** (front left), **POS F-RIGHT** (front right), **POS REAR** and **POS FRONT** until the desired setting is achieved.

After approximately five seconds with no further actions or adjustments, the audio system will return to the previous display.

Note: To improve the comfort of passengers in the rear of the vehicle, the bass performance of the subwoofer is reduced when DSP mode is set to **POS ALL** or **POS REAR**.

For optimum bass performance, do not select **POSS ALL** or **POS REAR**.

Mode level 2 - ADVANCED MODE

When **ADV MODE YES** is selected subsequent short presses of the **MODE** button will scroll through the available modes. When the desired mode is displayed, use the rotary volume control to adjust the setting.

Note: Mode level 2 can also be accessed via a long press of the **MODE** button.

Available modes

CLOCK FORMAT SET	Select 12 or 24 HR clock display. Press the MODE button to move to the next clock setting.
CLOCK HOUR SET	Adjust then press the MODE button to move to the next clock setting.
CLOCK MINUTE SET	Adjust then press the MODE button to save the clock settings and move to the next mode.

TA VOLUME	Increase/decrease.
VOICE VOLUME	Increase/decrease.
VOICE A	Press the 'seek up' button to adjust.
VOICE B	Press the 'seek up' button to adjust.

Press and hold the **MODE** button to exit.

The display will now revert to the screen in use before entering **CLOCK SET**.

Change audio system source



Press the desired audio system source button.

Source tone memory

Bass and Treble positions are automatically memorised for AM radio, FM radio and CD, allowing individual settings for each mode.

Band switch AM/FM

Pressing **AM/FM** repeatedly will cycle the radio through FM, Medium and Long Wavebands (as applicable). Band selection will be shown in the display panel. When a CD is being played, pressing the band switch will select radio operation.

Presetting memorised radio stations



WARNING:

In the interests of road safety, do not attempt to preset a station whilst driving.

Radio

On each waveband, nine stations can be memorised using keypad buttons **1** to **9**. After tuning to a station, press and hold the selected button until the unit 'beeps'. A station can be recalled from the preset memory by pressing and immediately releasing the button.

Pressing the steering wheel preset selector button will cycle through the preset stations.

Seek and manual tuning



In AM/FM mode, pressing and releasing the left or right button will activate the radio in seek mode, tuning through the frequency range to the next available station. Pressing either button for more than two seconds will enter manual tuning mode.

Auto Memory (A MEM)



The Automatic Memory function programmes the nine strongest stations on a selected waveband to presets **1** to **9**.

***Note:** These are additional to the preset stations described earlier.*

To activate this function, press and hold the **A MEM** button for at least two seconds.

The radio will be briefly muted while it searches the waveband for the nine strongest stations. When programming is complete the radio will default to preset number **1** and audio volume is restored.

If stations cannot be located for all preset positions, those that are found will be allocated positions commencing with number **1**, leaving the remainder not programmed. The display will show **NO FM** or **NO AM** if a selected preset is not programmed.

To switch between the A MEM preset stations and your own presets, press and immediately release the **A MEM** button.

A MEM with Radio Data System (RDS) selected

If the **A MEM** function is operated while in **RDS** mode, the radio will be muted briefly, while a search is made for the nine strongest RDS stations.

Radio Set Up

This function enables the radio to be set to user operating preferences. By selecting **SET UP** and using the preset buttons, the owner or Jaguar Dealer/Authorised Repairer can adjust certain radio functions.

When in **SET UP**, pressing the relevant preset button, as detailed below, will display the facility selected and its state. The state of that facility can be changed by pressing the preset button again.

To enter SET UP: Press **CD Eject** and **AM/FM** buttons simultaneously.

The display will show **SET UP**. The following preferences can be selected or changed in any order, within a 15 second period. After 15 seconds the display will clear and exit **SET UP**.

- | | |
|-----------------|--|
| Preset 1 | Press Preset 1 to enable or disable RDS availability in the user's country. |
| Preset 2 | Blank. |
| Preset 3 | Blank. |
| Preset 4 | Blank. |
| Preset 5 | Blank. |
| Preset 6 | FM volume high (compensate for poor signal strength). |
| | <i>Note: This feature is not available in North America, Australia and Japan.</i> |
| Preset 7 | Blank. |

Radio

Preset 8 Blank.

Preset 9 Blank.

Preset 10 During initial factory installation, this is used to set the radio to one of the following regions: Europe, USA, Australia or Japan. Regional settings determine the correct frequency increments required for seeking stations, automatic tuning etc.

Note: *The regions are preset at the factory. Should you require a regional change, consult your Jaguar Dealer/Authorised Repairer.*

Radio

RADIO WITH TOUCH-SCREEN

On/Off control



Press the control knob to switch the radio on, press again to switch off.



Pressing the **AUDIO** button can also turn on the radio. When using the touch-screen in other operating modes, such as Navigation, Television, Climate Control or any of the setup

screens, pressing the **AUDIO** button will revert to the relevant audio screen.

Volume control

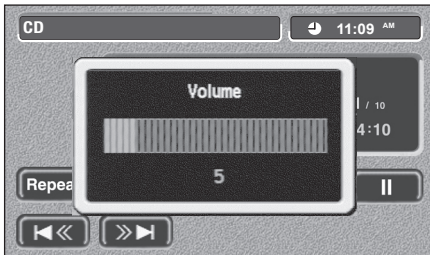

JAG0994

Turn the control knob clockwise to increase or counterclockwise to decrease volume, across a range of settings (0 – 35) to be displayed during and momentarily after adjustment.

When using the rotary control knob to adjust volume the touch-screen will show the above display to assist setting. The pop-up volume control slide will disappear from the display after five seconds or can be removed by touching it.

Any volume setting made whilst in Audio, Telephone or Navigation mode or JaguarVoice, will be memorised for that system.

Radio

Automatic Volume Control

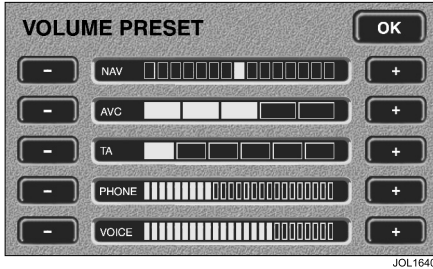

This maintains radio volume at a level sufficient to overcome road noise as vehicle speed increases or decreases.

To activate AVC, press the **MENU** button, followed by the **VOLUME PRESET** button on the touch-screen. Once in the volume preset screen, AVC level can be adjusted (from OFF to 5) by repeatedly pressing the + or – buttons adjacent to the AVC volume indicator.

When AVC is ON, manual adjustment of volume will override the AVC setting.

Volume preset adjustments

Volume for Telephone, JaguarVoice, TA and Navigation can also be adjusted by using the **MENU** button on the right of the screen and selecting the volume preset button as appropriate.

Audio setup



This function enables the radio to be set to user operating preferences. By selecting **SETUP** and using the buttons on the touch-screen, the owner or Jaguar Dealer/Authorised Repairer can adjust certain radio functions.

When in **SETUP**, pressing the relevant button will display the facility selected and its state. The state of that facility can be changed by pressing the button again.

To enter SETUP: Press **Eject** and **AM/FM** buttons simultaneously.

The display will show **AUDIO SETUP**. The preferences shown on the next page can then be selected or changed in any order. After 15 seconds the display will clear and exit **SETUP**.

Market

During initial factory installation, this is used to set the radio to one of the following regions: Europe, Australia or Japan. Regional settings determine the correct frequency increments required for seeking stations, automatic tuning etc.

Note: *The regions are preset at the factory. Should you require a regional change, consult your Jaguar Dealer/Authorised Repairer.*

Radio

- RDS/RBDS** Press ON/OFF buttons to enable or disable RDS, depending upon RDS availability in the user's country.
- FM Volume** FM volume high or low (compensate for poor signal strength).
- Note:** This feature is not available in Australia and Japan.*

Digital Signal Processing (DSP)

DSP (premium audio system only) facilitates optimisation of sound for specific seating positions and is accessed via the **DSP** button shown on the touch-screen (audio screens only). The chosen setting can then be selected by touching the appropriate zone.

Options available are:

- Front left.
- Front right.
- Front centre.
- Rear seats.
- All seats.

Radio

Change audio system source



Press the desired audio system source button.

AM/FM mode



JAG0996

In AM/FM mode, touch-screen buttons provide for station selection and retuning. In addition, the upper panel displays waveband, **TA** and **PTY** as selected using the buttons on the radio panel.

Band switch AM/FM

Pressing **AM/FM** repeatedly will cycle the radio through FM, Medium and Long Wavebands (as applicable). When a CD is being played, pressing the band switch will select radio operation.

Presetting memorised radio stations



WARNING:

In the interests of road safety, do not attempt to preset a radio station whilst driving.



On each waveband, nine stations can be stored in the bank of nine buttons displayed on the touch-screen. To store a radio station as a preset, touch the selected button until a beep sounds to acknowledge the station has been stored.

A station can be recalled from the preset memory by momentarily pressing any of the preset buttons. The selected preset is highlighted by a red halo around the appropriate button.

Pressing the steering wheel preset selector button will cycle through the preset stations.

Seek and manual tuning



In AM/FM mode, touch and release   to activate the radio in seek mode, tuning through the frequency range to the next available station. Pressing either button for more than two seconds will enter manual tuning mode.

Radio

Auto Memory (A MEM)



The Automatic Memory function programmes the nine strongest stations on a selected waveband to presets **1** to **9**.

***Note:** These are additional to the preset stations described earlier.*

To activate this function, press and hold the **A MEM** button for at least two seconds.

The radio will be briefly muted while it searches the waveband for the nine strongest stations. When programming is complete the radio will default to preset number **1** and audio volume is restored.

If stations cannot be located for all preset positions, those that are found will be allocated positions commencing with number **1**, leaving the remainder not programmed. The display will show **NO FM** or **NO AM** as appropriate.

To switch between the A MEM preset stations and your own presets, press and immediately release the **A MEM** button.

A MEM with Radio Data System (RDS) selected

If the **A MEM** function is operated while in **RDS** mode, the radio will be muted briefly, while a search is made for the nine strongest RDS stations.

Digital audio broadcasting (DAB)

GENERAL INFORMATION

Digital radio reception

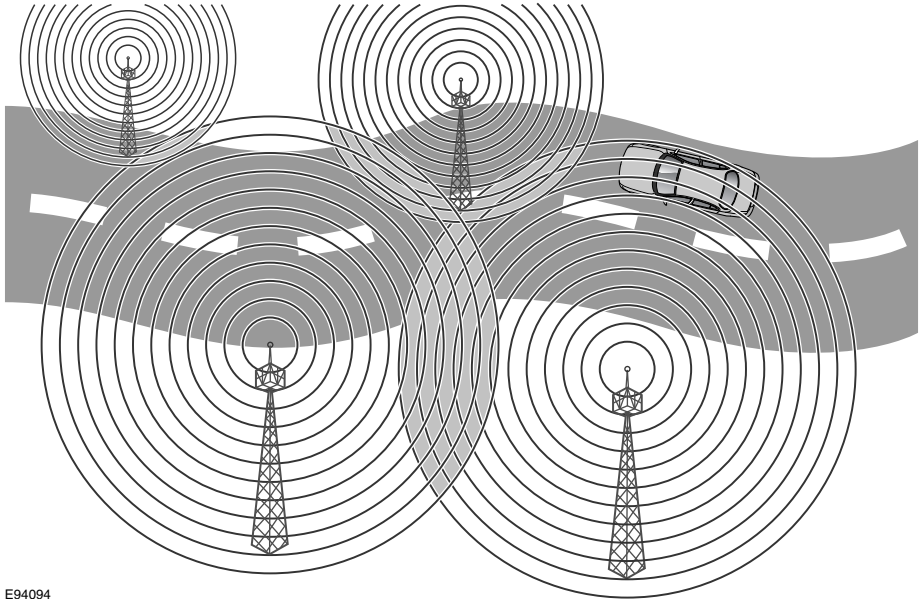

E94094

DAB radio is very different from normal AM/FM radio in both operation and sound quality. The DAB network is designed to provide near CD quality from radio broadcasts. In most locations DAB signals are available without hiss, crackle, pop or interference, and no fading or overlap.

DAB radio can significantly increase the number of radio channels/stations available. The DAB signals are transmitted to most major cities, towns and motorway networks.

Radio signals travel in a straight line so large obstacles, such as tall buildings, can shield the vehicle from the signal, causing temporary loss of reception (known as dead spots).

Digital radio is transmitted from regional transmitters. Some local channels are not available outside the range of their transmitters. If you want to listen to local channels as you move around the country, use the auto-tune function **TUNE** to build new channel lists.

Ensembles

Unlike AM/FM radio, DAB transmits several stations/channels on a single frequency. A group of stations/channels is known as an ensemble. Ensembles may consist of six or more stations/channels (national or local). Some may have sub-channels offering several listening options.

If reception is lost when the vehicle is in motion **No Reception** will be displayed.

Digital audio broadcasting (DAB)

The table below provides an example of the ensembles, channels and sub-channels available in one location.

Ensemble	Channel/Station	Sub-Channel 1	Sub-Channel 2
First ensemble	Channel/Station 1		
	Channel/Station 2	Sub-Channel	
	Channel/Station 3		
	Channel/Station 4		
	Channel/Station 5		
	Channel/Station 6	Sub-Channel	Sub-Channel
	Channel/Station 7		
	Channel/Station 8		
	Channel/Station 9		
	Channel/Station 10		
Second ensemble	Channel/Station 1		
	Channel/Station 2		
	Channel/Station 3		
	Channel/Station 4		
	Channel/Station 5		
	Channel/Station 6		
	Channel/Station 7		
Third ensemble	Channel/Station 1		
	Channel/Station 2		
	Channel/Station 3		
	Channel/Station 4		
	Channel/Station 5		
	Channel/Station 6		
	Channel/Station 7		
	Channel/Station 8		

DAB Touch-screen

AUDIO CONTROLS

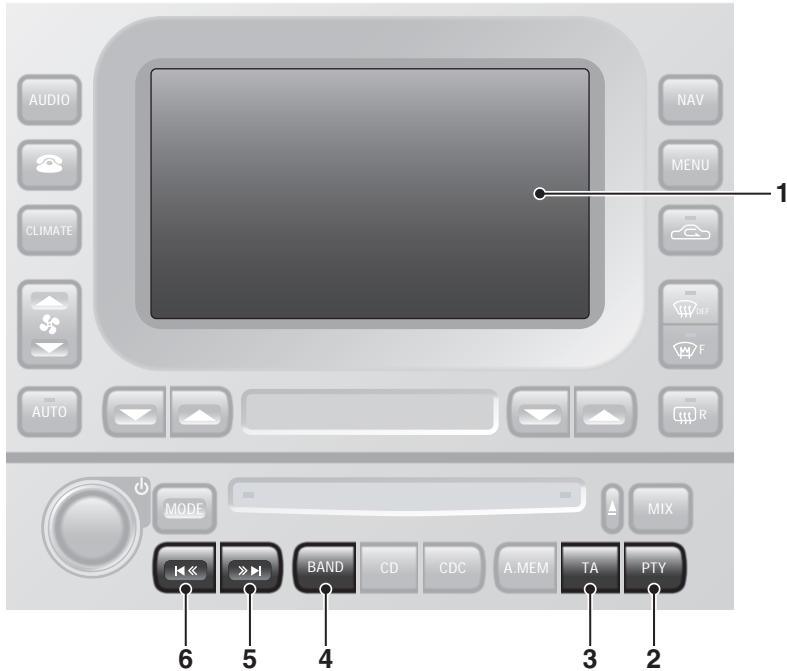

JAG0997

1. Touch-screen.
2. **PTY** button.
 - When PTY is selected programme information will be displayed.
3. **TA** button.
 - Press to enable or disable traffic announcements.
4. **BAND** button.
 - Press repeatedly to toggle through FM, MW/LW, DAB1, DAB2.
5. Seek up.
 - Short press to find the next channel.
 - Long press (two seconds) to find next available ensemble.
6. Seek down.
 - Short press to find previous channel.
 - Long press (two seconds) to find previous available ensemble.

DAB Touch-screen

Steering wheel controls

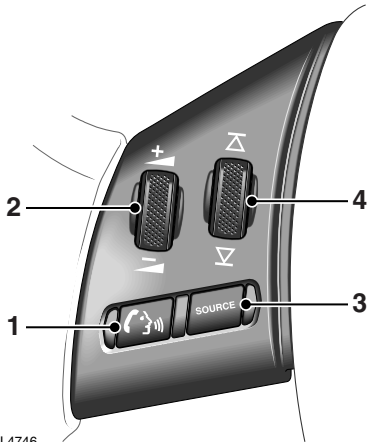

JOL4746

1. Start a voice command/Mute.
2. Rotate to increase or decrease volume.
3. Press the **SOURCE** button repeatedly to scroll through the available audio sources FM, MW/LW, DAB1, DAB2, CD, Auxiliary input and TV.
4. Rotate to scroll through DAB ensembles and stations/channels.

CHANNEL INFORMATION

Many digital channels transmit additional text (DLS, Dynamic Label Segment) to accompany a broadcast.

Additional information can be viewed by pressing **Info** repeatedly to scroll through the available information.



JAG0998

Note: For safety reasons, this text does not scroll across the screen. Therefore some of the text may be truncated.

DAB Touch-screen

CHANNEL AUTOMATIC TUNING

When you first use the DAB radio, you will be unable to listen to any digital broadcasts. **NO CHANNEL FOUND** will be displayed until you have completed the auto-tune process.



JAG0999

Press **TUNE** to start automatic tuning and build a list of all the digital ensembles and channels that are available in your region.

While automatic tuning is running, the message **DAB Auto-tune in progress** will be displayed on the touch-screen. When tuning is complete, the first channel found will start playing.

Note: The auto-tune process may take longer than one minute to complete.

To update the list of local channels when you move to a different region, select **TUNE** again. You can also add local channels as presets to minimise the need for auto-tuning as you move location.

CHANNEL OPTIONS

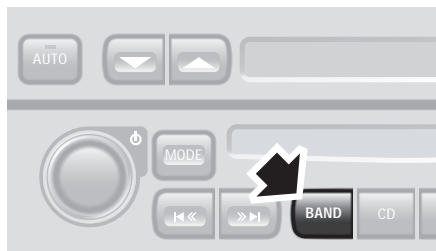

JAG1000

To receive digital broadcasts, short press the **BAND** button repeatedly to scroll through FM, MW/LW, DAB1, DAB2.

Choose **DAB1** or **DAB2** to receive digital radio broadcasts. The two DAB sources enable you to preset up to 18 different channels. **PRESET BUTTONS, 273**

The channel that was last played on your chosen digital source will be selected for playback automatically.

Note: If this is the first time you have used DAB radio, you must first build a list of available channels using the auto-tune function.

CHANNEL AUTOMATIC TUNING, 270

Digital radio channels are organised into groups called ensembles. Some channels may sometimes provide one or more subchannels.



JAG1001

DAB Touch-screen

If the digital radio signal is lost or the system takes time to tune in to a channel, then the display screen will show the message **No Reception**. If the signal is lost whilst another system is in use, navigation for example, a pop-up will display the **No Reception** message.

Finding an ensemble

Long press (two seconds) the seek buttons to find the next or previous ensemble. **AUDIO CONTROLS, 268**

After a few seconds pause, the first channel in the ensemble found will start playing.

Finding a channel

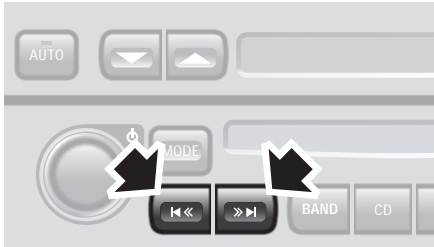

JAG1002

Short press one of the channel seek buttons to select the next available channel/station. The seek up button selects the next channel, the seek down button selects the previous channel.

Note: If the next or previous channel is in a different ensemble, then there will be a pause before the channel is located. The message **Searching...** is displayed on the screen.

On the touch-screen, if channels have been preset, select one of the six preset buttons to start playing that channel. If no channel has been preset, the button will display ---.

Finding a Subchannel



JAG1003

If subchannels are available within a channel an asterisk will be displayed at the end of the channel name.

Short press one of the seek buttons to select the next available Subchannel. The seek up button selects the next channel, the seek down button selects the previous channel.

DAB Touch-screen

DAB SEARCH

Ensemble list

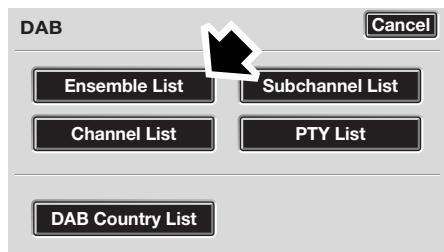

JAG0847

Select **Ensemble List** to display a list of all available ensembles. Select an ensemble name in the list to display a list of channels in that ensemble. Select a channel name to tune that channel.

Channel List

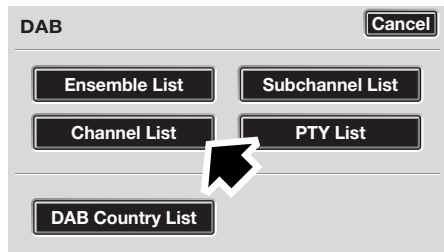

JAG0849

Select **Channel List** to display a complete list of all channels in all available ensembles. Select a channel name to tune that channel.

Subchannel List

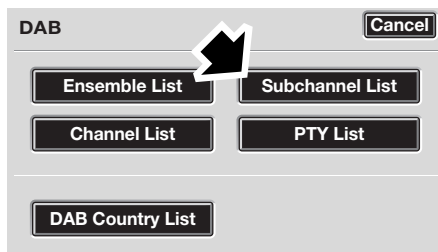

JAG0848

Select **Subchannel List** to display a list of any subchannels available for the currently tuned channel. If no subchannels are currently available, then the **Subchannel List** option is disabled. If the maximum five subchannels are available, then use the arrows to scroll through the list.

PTY

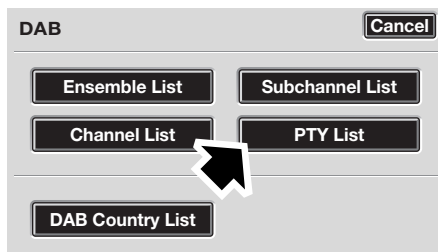

JAG0850

Channels are categorised by the broadcaster as belonging to a programme type (PTY) category. You can display a list of channels organised according to their PTY category.

Select **PTY** to display a list of PTY categories that contain channels. Select a PTY category to display a list of channels in that category. Select a channel name to play that channel.

DAB Touch-screen

Short press one of the seek buttons repeatedly during the first ten seconds of broadcast, to cycle through all channels contained in the PTY category that you chose.

PRESET BUTTONS

Storing channels as presets

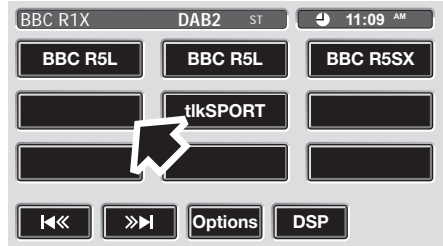

JAG1004

Store up to eighteen digital channels (nine each on **DAB1** and **DAB2**) using the preset keys. Follow the procedure below to store channels as presets.

1. Search for and start playing the channel you want to preset.
2. Long press (two seconds) the preset button on which you want to store the current channel. Audio output is muted for a further two seconds while the channel is stored and a confirmation tone is heard.
3. Repeat steps 1 and 2 for each channel that you want to store as a preset.

Note: You cannot store a subchannel as a preset. If you try to store a subchannel, you will store the channel to which the subchannel belongs.

DAB Touch-screen

Recalling a preset channel



JAG1005

Make sure that you have selected the appropriate digital source (**DAB1** or **DAB2**) and then short press the preset button you require. The channel you have selected will start to play automatically.

Note: If you try to recall a channel that has previously been stored as a preset but is now unavailable or invalid, the message **No channel found** is displayed. You must choose another channel.

SETTINGS

Traffic Announcements

You can select **Traffic Announcements** when listening to DAB.

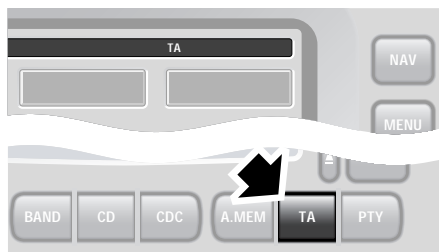

JAG0854

When a traffic announcement is broadcast, it will interrupt normal play for the duration of the announcement.

Note: If traffic announcement (TA) has been selected whilst listening to an FM station, it will de-select when DAB is selected using the band button. To continue TA coverage during DAB broadcasts press the TA button with DAB selected.

DAB country

If you move the vehicle to a different country, you can change **DAB Country** option to make sure that you receive the best possible reception and sound quality.

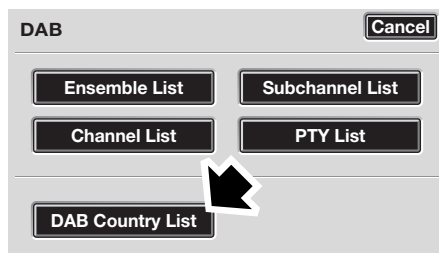

JAG0851

DAB Touch-screen

Select **DAB Country** to display a list of countries where DAB services are available. Select the country name to enable it.



JAG0860

Note: When you change the DAB country, the audio unit will automatically start auto-tuning. If you **Cancel** the auto-tune, the country setting will remain changed but you may not have access to all available ensembles for that country. **CHANNEL AUTOMATIC TUNING, 270**

Note: For safety reasons this option is disabled when the vehicle is moving.

DAB format



JAG0861

Different regions or countries may use different digital bands to broadcast DAB channels. If you know the band(s) required then you can choose from the **Band selection** list.

Select **Change** to display a list of formats. The available bands are:

- LBand
- BandIII
- LBand & BandIII
- LBandCanada
- LBandCan & BandIII

Note: When you change the DAB format, the audio unit will automatically start auto-tuning. If you cancel the auto-tune, the new format setting will remain, but you may not have access to all available ensembles for that format.

Note: For safety reasons this option is disabled when the vehicle is moving.

DAB Standard audio

AUDIO CONTROLS

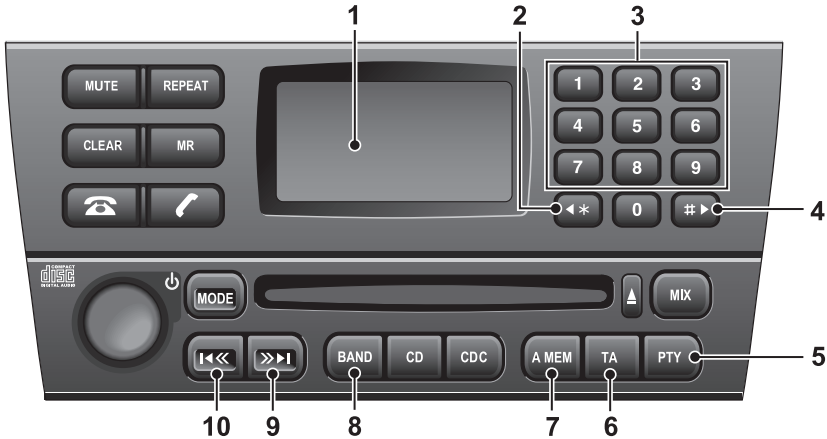

JAG1006

1. Information display screen
2. Secondary Channel/Station search up.
Press and release to find the next subchannel when available.
3. Keypad buttons. Preset store and recall
4. Secondary Channel/Station search down.
Press and release to find previous subchannel when available.
5. PTY button. Press repeatedly to display programme type information.
6. TA button. Press to enable or disable traffic announcements. **TA** is displayed when active.
7. A.MEM button. Briefly press to start auto tune process. Press and hold to display country information and bands.
8. BAND button.
Press and release to select the next available radio band FM, MW, LW, DAB1, DAB2
9. Ensemble and Channel/Station search up.
Press and hold to find the next digital station.
Press and hold to find the next ensemble.
10. Ensemble and Channel/Station search down.
Press and release to find previous digital station.
Press and release to find previous ensemble.

DAB Standard audio

SELECTING DAB

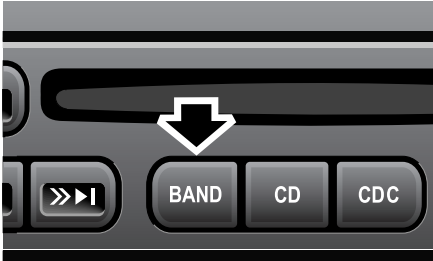

JAG0866

To receive digital broadcasts, press the **BAND** button repeatedly to toggle between the **FM1**, **MW/LW**, **DAB1** and **DAB2**. Choose either **DAB1** or **DAB2** to receive digital broadcasts. The channel that was last played on your chosen digital source will be selected for playback automatically.

Note: If this is the first time you have used DAB, before you can select a channel, you need to build a list of available channels using the auto-tune function.

CHANNEL AUTOMATIC TUNING



JAG1007

Note: When you first use your DAB radio, you will be unable to listen to any digital stations until you have used the auto-tune function. The message **No Channel** will be displayed.

Briefly press the **A.MEM** button to start automatic tuning and build a list of all the digital ensembles and channels/stations available in your current location.

Note: The auto-tune process may take longer than one minute to complete.

While automatic tuning is running, the message **PLEASE WAIT** will be displayed. When tuning is complete, the first channel in the first ensemble found will start playing.

To update the list of local channels when you move to a different region, press the **A.MEM** button again.

DAB Standard audio

ENSEMBLES

Digital radio channels are organised into groups called ensembles.

Selecting an ensemble

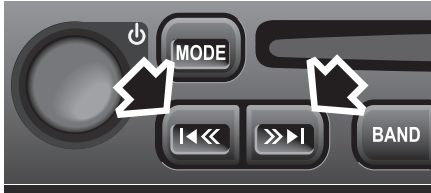

JAG1008

Press and hold the up (>|) button to find the next ensemble, the down (|<) button finds the previous ensemble. After a short delay the first channel in the ensemble you have selected will play.

CHANNEL OPTIONS

Selecting a channel

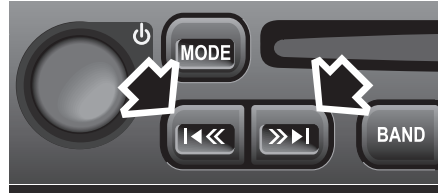

JAG1008

Briefly press the up (>|) button to find the next station/channel, the down (|<) button finds the previous station/channel.

Note: If the next or previous channel is in a different ensemble, then there will be a short delay before the channel is located. The message **SEARCHING** is displayed on the screen.

Selecting a subchannel

If subchannels are available under the channel you have selected, the subchannel * is displayed in front of the station name.



JAG0869

Briefly press the up (#>) button to find the next subchannel, the down (<*) button finds the previous subchannel.

Note: when you select and play a subchannel, the * is replaced by **SubCh** on the display screen.

DAB Standard audio

Signal availability



If the digital radio signal is lost or the system takes time to tune in to a channel, then the display screen will show the message **No reception**.

The problem may be caused by a temporary problem, such as buildings or trees blocking the signal, or it might be a problem with the broadcast service operator. Try tuning to an alternative channel and return later to see if the problem has been resolved. If you are unable to tune to any other channels, you may need to press **A.MEM** to build a new list of ensembles.

PRESET BUTTONS

Storing channels as presets



You can store up to eighteen digital channels (nine each on **DAB1** and **DAB2**) using the numbered preset buttons.

1. Search for and start playing the channel you want to preset.
2. Press and hold the preset button (for about two seconds) on which you want to store the current channel. Audio output is muted for a further two seconds while the channel is stored and a confirmation message is displayed.
3. Repeat steps 1 and 2 for each channel that you want to store as a preset.

Note: You cannot store a subchannel as a preset. If you try to store a subchannel, you will store the channel to which the subchannel belongs.

Recalling a preset channel



DAB Standard audio

Make sure that you have selected the appropriate digital source (**DAB1** or **DAB2**) and then press and release the preset button you require. The channel you have selected will start to play automatically.

Note: If you try to recall a channel that has previously been stored as a preset but is now unavailable or invalid, the message **No channel found** is displayed. You must choose another channel.

DAB COUNTRY

DAB format



JAG1012

Different regions or countries may use different digital bands to broadcast DAB channels.

Press and hold the **A.MEM** button to display the current format. Once the current format is displayed, repeatedly press the A.MEM button to scroll through the bands. Select the country you are in, or if you know it, the correct band.

- LBand
- BandIII
- LBand & BandIII
- LBandCanada
- LBandCan & BandIII

Note: When you change the DAB format, the audio unit will automatically start auto-tuning. If you **Cancel** the auto-tune, the new format setting will remain, but you may not have access to all available ensembles for that format. **CHANNEL AUTOMATIC TUNING, 270**

DAB Standard audio

DAB country selection



JAG1013

If you move the vehicle to a different country, you can change **DAB country** setting. This will ensure that the audio unit receives all of the available ensembles, and provides the best possible reception and sound quality. Press and hold the **A.MEM** button to display the first country in the list. Use the (>|) (|<) buttons to scroll through the country list. When the required country name is displayed briefly press the **A.MEM** button to select the country and start the auto-tune process.

PTY

Press and release the **PTY** button to display a list of programme types.

Use the (>|) (|<) buttons to scroll up or down through the list of programme types. Once the required type is displayed briefly press the **PTY** button to display a list of stations within that category.

Use the (>|) (|<) buttons to scroll up or down through the station list. Once the required station is displayed briefly press the **PTY** button to tune to that station.

Note: If no selections are made, or the scroll buttons are not used for 5 seconds the **PTY** display will cancel automatically.

Note: If no programme types are available then **NO DAB PTY** will be displayed.

Single CD Player

SINGLE CD PLAYER - STANDARD AUDIO

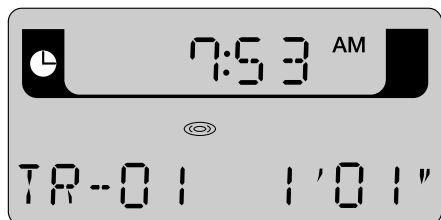

JOL1634

The audio display will indicate which function has been selected. Messages include; **LOADING**, **EJECTING**, **MIX TRACKS**, **REPEAT TRACK**, **PAUSED** and **CUE/REVIEW**.

Inserting a CD into the CD aperture will start immediate play. The display will show **LOADING**, followed by **TR-01 00' 00\"**. The CD symbol will also be displayed until the CD is ejected, regardless of the selected audio source.

Eject and CD-in indicator

 When a CD is inserted, the CD icon is displayed. Press to eject the CD. The display will show **DISC EJECT** and the CD icon will be turned off.

MIX

 To play random tracks from the disc, press and release the **MIX** button. **MIX** will be displayed. To cancel, press the **MIX** button again.

CD button

 If you are playing the radio or CD changer, pressing the **CD** button will resume playing any CD installed in the player mechanism.

The audio display will show **TR-NN MM' SS\"**, where **NN** is the current track number and **MM SS** is the track time in minutes and seconds.

Pressing the **CD** button while in CD play mode will pause the current track, the display will show **TR-NN PAUSE** where **NN** is the current track number. A subsequent press of the **CD** button will resume play mode.

This function can also be controlled by a switch on the steering wheel.

REPEAT



Press and release the **REPEAT** button to repeat the current CD track being played. To cancel, press the **REPEAT** button again.

Seek up and down



This control selects seeking of tracks up or down.

Momentarily press the right-hand button to skip to the next track. Repeated pressing will select further tracks.

The left-hand button returns to the beginning of the current track. Repeated pressing selects previous tracks.

Pushing and holding either button selects cue and review of the CD.

Note: *Sound level is reduced when cueing and reviewing a CD.*

Single CD Player

SINGLE CD PLAYER WITH TOUCH-SCREEN



JAG1014

- 1. AUDIO.** Press to turn the audio system ON, or to display relevant audio screen and associated touch-screen buttons.
- 2.** Touch-screen display.
- 3. MENU.** Press to access touch-screen options.
- 4. MIX.** Mix CDs or CD tracks playing order.
- 5. PTY.** Priority Programme Type (where broadcast).
- 6. TA.** Traffic Announcement and Radio Data System (where broadcast).
- 7. A MEM.** Automatically set station presets.
- 8. CDC.** Select CD changer.
- 9. CD.** Select compact disc play when in other audio mode, or CD pause (when a CD is inserted and playing).
- 10. AM/FM.** Radio waveband select.
- 11.** Seek AM/FM station, cue/review CD.
- 12. MODE.** Scroll to select sound settings.
- 13.** ON/OFF and volume control.
- 14.** Eject CD.



JAG1015

Single CD Player

In **CD** mode, touch-screen buttons (shown above) provide selection of CD tracks.

The display will show the CD screen. The CD symbol will be displayed until the CD is ejected, regardless of the selected audio source.

Inserting a CD into the aperture will start it playing.

Eject



Press to eject the CD.

Mix



To play random tracks from the disc, press and release the **Mix** button. **MIX** will be displayed. To cancel, press the **Mix** button again.

Repeat



Press and release the **Repeat** button to repeat the current CD track being played. To cancel, press the **Repeat** button again.

Pause



Touch the pause button to pause CD play.

Note: *Pause button function changes to a play button, a subsequent press will resume CD play.*

CD button



If you are playing the radio or CD changer, pressing **CD** will play the CD in the player. This function can also be controlled from the appropriate button on the steering wheel see 'Steering Wheel Controls', page 252.

Seek up and down



Touch and release to seek tracks up or down.

Momentarily press the right-hand button to skip to the next track. Repeated pressing will select further tracks.

The left-hand button returns to the beginning of the current track. Repeated pressing selects previous tracks.

Pushing and holding either button selects cue and review of the CD.

Note: *Sound level is reduced when cueing and reviewing a CD.*

Compact Disc Changer

COMPACT DISC (CD) CHANGER OPERATION

A CD changer is installed in the luggage compartment and will accommodate up to six discs, each mounted in a tray.

Caution: The 8 cm diameter discs and associated adaptors available in some countries must not be installed in the CD changer magazine. Any attempt to install these items can result in permanent damage to the CD changer mechanism.

CD check sequence

When the CD player is switched on, a check is performed on each disc tray in the CD changer magazine. When the six trays have been checked the player returns to the first disc in the magazine.

Loading discs and inserting magazine

Loading a disc into a magazine tray: Slide the magazine door to the right (1). Press the eject button (2), the magazine will then partly eject from the CD changer. Pull the disc tray from the magazine (3). Ensuring the playing surface is not touched, load a selected disc into the tray with the label facing upwards (4). Push the tray back into the magazine until it clicks. Tray slots are numbered 1 (bottom) to 6 (top).

Inserting the magazine: With the arrow mark facing upwards and pointing towards the CD changer, insert the loaded magazine into the CD changer (5) ensuring that it clicks into position. Close the sliding door. Keep the sliding door closed to prevent dust entering the playing mechanism.

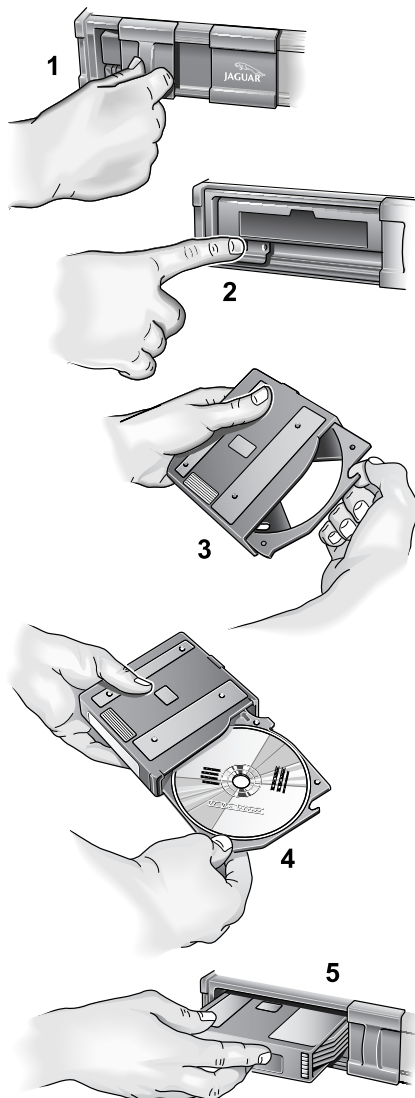

JOL3299

Compact Disc Changer

CD CHANGER - STANDARD AUDIO

CD changer mode

The audio display indicates the CD and track being played, and CD status.

Below is an example of the display when playing track 1 from CD 4.

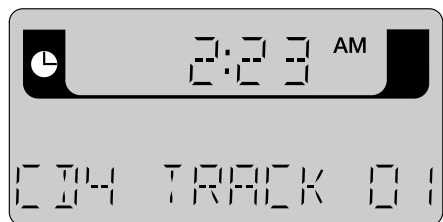

JOL_1244

Other messages:

CD1 LOADING	CD1 is being loaded.
NO DISC	In the selected position.
NO MAGAZINE	In the CD autochanger.
CD1 MIX 10	The player is playing CD1 in MIX mode (track 10).
D MIX	All CDs are in MIX mode.
MAG EJECT	Magazine is being ejected.
PAUSED	The CD changer is paused and ready to play.

CDC button

 Press **CDC** to select CD changer mode.

This function can also be controlled from the appropriate switch on the steering wheel.

CD selection



Preset buttons **1** to **6** select the compact discs in those positions in the magazine. If there is no disc in the selected position, **NO DISC** will be displayed. If there is no magazine in the CD changer, **NO MAGAZINE** will be displayed.

MIX

 To play random tracks from the disc, press and release the **MIX** button. **MIX** will be displayed. To cancel, press the **MIX** button again.

To play random tracks from all discs present in the magazine, press the **MIX** button for two seconds. **DISC MIX** will be momentarily displayed, followed by **D MIX**. To cancel, press and hold the **MIX** button.

Seek up and down

 This control selects seeking of tracks up or down. Momentarily press the right-hand button to skip to the next track. Repeated pressing will select further tracks.

The left-hand button returns to the beginning of the current track. Repeated pressing selects previous tracks.

Pushing and holding either button selects cue and review of the CD.

***Note:** Sound level is reduced when cueing and reviewing a CD.*

REPEAT

 Momentarily press the **REPEAT** button to repeat the current CD track being played, **R-ONE** will be displayed. To cancel, momentarily press the **REPEAT** button again.

Compact Disc Changer

Press and hold the **REPEAT** button for two seconds to repeat the current CD, **R-ALL** will be displayed. To cancel, press and hold the **REPEAT** button again for two seconds.

Pause



When playing a CD, press the **CDC** button to pause play. Press again to continue play.

CD CHANGER WITH TOUCH-SCREEN

CD changer mode



JAG1016

In CD changer mode, touch-screen buttons (shown above) provide for track and disc selection. Discs present in the magazine are highlighted in the display.

A disc is selected by touching the appropriate disc button which, when playing, has a red active surround.

The track and track duration are displayed during play.

CDC button



Press **CDC** to select CD changer mode.

Note: This function can also be controlled from the appropriate button on the steering wheel (see 'Steering Wheel Controls', page 252).

Mix and CD mix



To play random tracks from a selected disc, press and release the **Mix** button. **MIX TRACKS** will be displayed. To cancel, touch the **Mix** button again.

To play random tracks from all discs present in the magazine, touch and hold the **Mix** button for more than two seconds. **MIX ALL** will be displayed. To cancel, touch and hold the **Mix** button.

Compact Disc Changer

Seek up and down



Touch and release to seek tracks up or down.

Momentarily press the right-hand button to skip to the next track. Repeated pressing will select further tracks.

The left-hand button returns to the beginning of the current track. Repeated pressing selects previous tracks.

Pushing and holding either button selects cue and review of the CD.

Note: *Sound level is reduced when cueing and reviewing a CD.*

Repeat



Momentarily press the **Repeat** button to repeat the current CD track being played. **REPEAT TRACK** will be displayed. To cancel, momentarily press the **Repeat** button again.

Press and hold the **Repeat** button for two seconds to repeat the current CD. **REPEAT DISC** will be displayed. To cancel, press and hold the **Repeat** button again for two seconds.

Pause



Touch the pause button to pause CD play.

Note: *Pause button function changes to a play button, a subsequent press will resume CD play.*